

Towa Corp v ASM Technology Singapore Pte Ltd and another
[2016] SGHC 280

Case Number : Suit No 359 of 2013
Decision Date : 22 December 2016
Tribunal/Court : High Court
Coram : Lee Seiu Kin J
Counsel Name(s) : Low Chai Chong, Long Ai Ming, Foo Maw Jiun and Ng Chong Yuan (Dentons Rodyk & Davidson LLP) for the plaintiff; Lim Ying Sin Daniel (Joyce A. Tan & Partners LLC) for the defendants.
Parties : Towa Corporation — ASM Technology Singapore Pte Ltd — ASM Pacific Technology Limited

Patents and inventions – Defence

Patents and inventions – Groundless threat

Patents and inventions – Infringement

Patents and inventions – Inventive step

Patents and inventions – Novelty

Patents and inventions – Validity

[LawNet Editorial Note: The appeal to this decision in Civil Appeal No 9 of 2017 was dismissed by the Court of Appeal on 5 January 2018. See [\[2018\] SGCA 1.](#)]

22 December 2016

Judgment reserved.

Lee Seiu Kin J:

1 The plaintiff, Towa Corporation, is a company incorporated in Japan. The plaintiff is the registered proprietor of Singapore Patent No 49740 (“the Patent”). The first defendant, ASM Technology Singapore Pte Ltd, is a company incorporated in Singapore and is a wholly-owned subsidiary of the second defendant, ASM Pacific Technology Limited, which is a company incorporated in the Cayman Islands but with its registered address in Hong Kong. The Patent expired sometime in 2014, although parties seem to differ on the exact date of expiry.

2 In this suit (“the Suit”) the plaintiff claims against the defendants for infringement of the Patent. The infringing acts alleged by the plaintiff concern a product known as the IDEALmold machine. The defendants oppose the plaintiff’s claim on various grounds. They also counterclaim against the plaintiff for making groundless threats of infringement proceedings pursuant to s 77 of the Patents Act (Cap 221, 2005 Rev Ed) (“Patents Act”).

3 The Suit has been bifurcated and the trial proceeded on the issue of liability.

Facts

Brief background to moulding technology and moulding machines

4 The Patent concerns moulding technology and moulding machines. Moulding is the process of injecting molten thermo-setting plastics on top of electronic circuitry. Thermo-setting plastics (also referred to as "resin") are made up of polymer materials with the unique characteristic of being liquid or malleable but capable of undergoing an irreversible hardening process through curing (which is usually induced by heat) to become an infusible and insoluble polymer network.

5 The moulding process encapsulates the electronic circuitry with resin. This involves a process of softening the resin with heat and injecting the resin into a mould under high pressure. The end result is a layer of resin encasing and sealing the electronic circuitry, which protects it from heat and environmental hazards.

6 In the 1970s, the moulding process involved a substantial amount of manual input from the operator. A typical moulding machine would comprise a mould as shown in the following diagram:

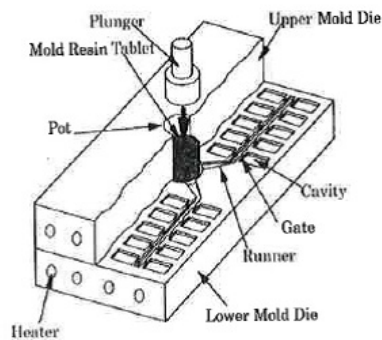

7 A moulding machine back then was essentially the mould (also called a "mould chase") and a pressing mechanism which was used to operate the moulds. The mould chase with the pressing mechanism is usually referred to as a "mould press". The moulding machine would operate as follows:

- (a) Pre-heated resin tablet is manually placed into the pot.
- (b) A lead frame (containing the electronic circuitry) is manually placed into the cavity.
- (c) The lower and upper mould dies would come together through the operation of the pressing mechanism.
- (d) The plunger compresses the resin and the resin flows through the runners into the cavities, encapsulating the lead frame in the process.
- (e) The sealed lead frame is manually removed from the moulding machine after the resin cools and hardens.

8 The early 1990s, however, saw the advent of fully-automated moulding machines. In addition to having automated moulding presses, these machines automated the previously manual processes of loading and unloading the resin tablets and lead frames.

The parties' pleaded cases

The plaintiff's pleaded case

9 The plaintiff's pleaded case is that the defendants have infringed Claims 1, 2, 4 and 5 of the Patent by doing the following acts in Singapore without the consent of the plaintiff:

- (a) The first defendant has offered for use, in Singapore, the IDEALmold machine which infringes Claims 1 and 2 of the Patent.
- (b) The first defendant has made, kept, offered to dispose and disposed of, in Singapore, the IDEALmold machine which infringes Claims 4 and 5 of the Patent.
- (c) The second defendant has made and kept, in Singapore, the IDEALmold machine which infringes Claims 4 and 5 of the Patent.
- (d) Both defendants have jointly, pursuant to a common design, made, kept, offered for use, offered to dispose and disposed of, in Singapore, the IDEALmold machine which infringes Claims 1, 2, 4 and 5 of the Patent.

10 Thus, the plaintiff asks for: (a) a declaration that the Patent has been infringed by the defendants; (b) an inquiry as to damages or, alternatively, at the plaintiff's option, an account of profits and an order for payment of all sums found due upon making such inquiry or account; and (c) interest. In addition to these, the plaintiff had originally asked for an injunction. However, in closing submissions, this was conceded to be an inappropriate remedy in light of the Patent's expiry. The plaintiff had also originally asked for an order for delivery up or destruction upon oath, but ultimately accepted, in oral submissions, that it is "not really pressing" for this.

The defendants' pleaded case

11 The defendants oppose the plaintiff's claim on grounds that can be summarised as follows:

- (a) The Patent is invalid for lack of novelty, inventive step and sufficiency.
- (b) The IDEALmold machine merely embodies the teaching of an apparatus previously disclosed in the prior art available before the priority date of the Patent without substantial or patentable variation, such that any act made with respect to the IDEALmold machine did not, and could not, infringe the Patent.
- (c) The claims of the Patent do not cover the IDEALmold machine.
- (d) Neither of the defendants used or offered the use of the method covered by Claims 1 and 2 of the Patent with respect to the IDEALmold machine in Singapore.
- (e) The defendants did not have knowledge, and in the circumstances it was not obvious to a reasonable person, that the alleged making, keeping, offer for use, offer to dispose or disposal of the IDEALmold machine may constitute use of the process in Claims 1 or 2 of the Patent.
- (f) The second defendant is an investment holding company and was not involved in manufacturing or sales operations at all material times.
- (g) There was no common design.
- (h) The plaintiff has been aware, or should reasonably have been aware, of the IDEALmold machine since 1999/2000 and, therefore, s 6 of the Limitation Act (Cap 163, 1996 Rev Ed)

("Limitation Act") and the defences of estoppel, delay, laches and acquiescence apply.

12 In addition, the defendants also rely on ss 69(1) and 70 of the Patents Act. They further counterclaim against the plaintiff for making groundless threats of infringement proceedings pursuant to s 77 of the Patents Act.

13 In these premises, the defendants ask for: (a) a declaration that Claims 1, 2, 4 and/or 5 of the Patent are invalid and/or are not infringed by the defendants; (b) an order that Claims 1, 2, 4 and/or 5 of the Patent be revoked; (c) a declaration that the plaintiff's threats are unjustifiable; (d) an injunction against the continuance of the plaintiff's threats; and (e) damages in respect of any loss the defendants have sustained by the threats.

The asserted claims

14 From the above, it is apparent that a total of four claims (*viz*, Claims 1, 2, 4 and 5) are in issue in the Suit. In so far as these claims are concerned:

- (a) Claims 1 and 2 are *process* claims while Claims 4 and 5 are *product* claims.
- (b) Claim 2 is dependent on Claim 1 and Claim 5 is dependent on Claim 4.
- (c) Claim 1 is similar to Claim 4 in that Claim 1 teaches the process whereby the moulding machine taught in Claim 4 is operated.

15 In light of this, the plaintiff has suggested (rightly, in my view) that I focus my attention on Claim 4. In this regard, the disputed part of Claim 4 reads as follows:

An apparatus for molding resin to seal electronic parts, comprising:

...

additional molding units (5a, 5b, 5c) being rendered detachably mountable with respect to already provided said molding unit (5), thereby freely increasing/decreasing the number of said molding units.

Issues

16 Drawing the various threads together, the broad issues that arise for my determination in the Suit are as follows:

- (a) What is the proper construction of the Patent claims (in particular, Claim 4)?
- (b) Is the Patent (in particular, Claim 4) valid?
- (c) If the Patent is valid, are the defendants *prima facie* liable for infringing the Patent?
- (d) If the defendants are *prima facie* liable for infringing the Patent, are there any defences available to them?
- (e) If the Patent is not valid and/or the defendants are not liable for infringing the Patent, is the plaintiff liable for making groundless threats of infringement proceedings?

17 In this judgment, the English spelling for “mould” will be used except where the word is cited from a document which adopts the American spelling.

What is the proper construction of the Patent claims (in particular, Claim 4)?

The law

18 I turn to the first broad issue, *viz*, what is the proper construction of the Patent claims (in particular, Claim 4)? In this regard, s 113(1) of the Patents Act provides that an invention for a patent for which a patent has been granted shall, unless the context otherwise requires, be taken to be that specified in a claim of the specification of the patent, as interpreted by the description and any drawings contained in that specification.

19 In *First Currency Choice Pte Ltd v Main-Line Corporate Holdings Ltd and another appeal* [2008] 1 SLR(R) 335 (“*First Currency Choice*”), the Court of Appeal observed (at [23]) that in ascertaining the true construction of a patent specification, the claims themselves are the principal determinant, while the description and other parts of the specification may assist in the construction of the claims. The court then went on to hold (at [24]) as follows:

As the necessary background of the words used in the claims may be affected or defined by what is said in the body of the patent specification, *the claims should not be viewed independently, but should instead be construed as part of the whole specification* ... However, it is not permissible to put a gloss on or expand the claims by relying on a statement in the specification. *If the claims have a plain meaning, then reliance ought not to be placed on the language used in the body of the specification so as to make them mean something different* ... Claims must be read and given their ordinary and natural meaning without incorporating extracts from the body of the specification into them. [emphasis added]

Thus, in construing a patent claim, regard can (and should) be given to the description and drawings of the patent, so long as these are not used to alter the plain meaning of the claim.

20 In addition, the Court of Appeal has repeatedly endorsed a purposive approach to claim construction (see, for example, *Bean Innovations Pte Ltd and another v Flexon (Pte) Ltd* [2001] 2 SLR(R) 116 (“*Bean Innovations*”) at [19]; *First Currency Choice* at [25]). This approach posits that a patent specification “should be given a purposive construction rather than a purely literal one derived from applying to it the kind of meticulous verbal analysis in which lawyers are too often tempted by their training to indulge” (*Catnic Components Limited and another v Hill & Smith Limited* [1982] RPC 183 at 243). However, the Court of Appeal has also cautioned that the purposive approach “does not mean that the court in construing a claim is entitled to disregard the clear and unambiguous words used to describe the essential features of a claim” (*Bean Innovations* at [27]). Thus, “[e]ven adopting a purposive construction, one cannot write words into a claim that are not there or give a meaning to a term of a claim that is contrary to its language” (*Bean Innovations* at [27]).

21 Finally, claim construction is done through the eyes of the person skilled in the art (*First Currency Choice* at [27]–[28]).

Analysis

22 The plaintiff submits that the invention, which is described in Claim 4 of the Patent, is:

... the application of the concept of modularity to the molding units of molding machines. The

Patent teaches how this modularity can be achieved by having molding machines with molding units which are "detachably mountable" (i.e. detachable and attachable) to each other, so as to enable a customer who has bought such a molding machine, the flexibility of subsequently increasing or decreasing the number of molding units according to desired production capacity.

At trial, the defendants' expert, Dr Michael Pecht ("Pecht"), appeared to have substantially agreed with the essential elements of the above characterisation. On my part, I agree with the plaintiff's interpretation of Claim 4. However, this is not the end of the matter, as there still remains differences between the parties.

Definition of "molding unit"

23 The most critical of these differences relates to the definition of the term "molding unit". The difference in the parties' positions is best explained by a reference to Figure 3 of the Patent:

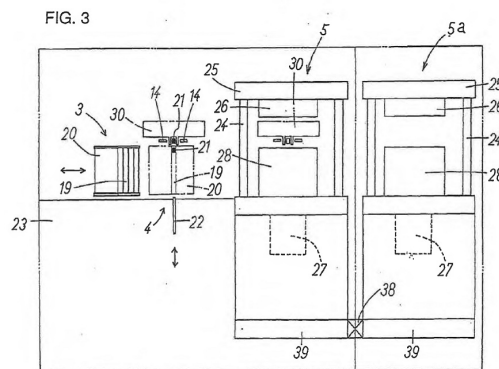

24 There are two similar structures in this figure, one around the middle of the figure and another on the right. For present purposes, it suffices to look only at the structure on the right. Pecht is of the view that the term "molding unit" refers only to the top half of this structure, *ie*, the part of the structure within numerals 25, 26, 24 and 28. Pecht's view is based on an earlier part of Claim 4, which reads as follows:

An apparatus for molding resin to seal electronic parts, comprising:

a molding unit having a mold (26, 28), resin material supply pots being arranged in said mold, resin pressurizing plungers being provided on said pots, cavities being provided in mold surfaces of said mold, and resin passages being arranged between said pots and said cavities.

25 On the other hand, the plaintiff's expert, Haruo Tabata ("Tabata"), takes the view that the term "molding unit" refers to the *entire* structure. To Tabata, the term "molding unit" comprises not only the mould (which is indicated by the numerals 26 and 28), but also the pressing mechanism (which is indicated by numeral 27).

26 In my judgment, the term "molding unit" refers, as suggested by Tabata, to the entire structure. I do not think that the part of Claim 4 relied on by Pecht (see [24] above) is intended to set out a definition (much less an exhaustive definition) of what a "molding unit" comprises. Indeed, the defendants accept that the elements listed in this part of Claim 4 are not exhaustive. This being the case, I do not see anything else that can give rise to the restrictive interpretation suggested by Pecht.

27 On the contrary, the description and Figure 3 of the Patent indicate that the term "molding

unit" refers to the entire structure. In the specification, the term "molding unit" is indicated by the numerals 5, 5a, 5b and 5c at various junctures, including in the disputed part of Claim 4. When one looks at Figure 3 of the Patent, it is sufficiently clear that the numerals 5 and 5a refer to the two structures in their entirety. This interpretation is further supported by the following extracts from the description, which suggest that the term "molding unit" includes the components indicated by numerals 27 and 39 and, therefore, refers to the entire structure:

The molding unit 5 is provided with a fixed plate 25 which is fixed to an upper part of an apparatus body 23 through tie-bars 24, a fixed upper mold section 26 which is mounted on the fixed plate 25, a movable lower mold section 28 which is oppositely arranged under the fixed upper mold section 26 to be vertically driven by a required mold switching mechanism 27, and a plurality of (seven in Fig. 1A) pots 29 which are arranged on the movable lower mold section 27.

...

Engaging means 38 is provided on a right end portion of a bottom base 39 of the molding unit 5, to be coupled with another molding unit as described later.

28 As I have mentioned earlier, regard can (and should) be given to the description and drawings of the patent in construing a patent claim (see [19] above). Moreover, given my observation at [26] above, this is not a case where the description and Figure 3 of the Patent are being used to alter the plain meaning of the claim. Thus, I find that the term "molding unit" refers to the entirety of each of the two structures in Figure 3.

Meaning of "freely increasing/decreasing"

29 A second difference between the parties' positions is the meaning of the phrase "freely increasing/decreasing" in the disputed part of Claim 4. Pecht's view, as I understand it, is that the word "freely", alongside other words in the Patent such as "arbitrarily", "simply" and "readily", means that Claim 4 excludes machines which require complex and time-consuming attachment/detachment and positioning operations to be performed when increasing or decreasing the number of moulding units. Relying on other parts of the description, Pecht also suggests, albeit in the context of Claim 1, that adjusting the number of moulding units has to be "relatively quick and easy" and that adjustments which take "significant time", or which require "new components to be added" or "significant costs", fall outside Claim 1. Tabata, on the other hand, opines that "freely increasing/decreasing" the number of moulding units simply means that because the moulding units are "detachably mountable", the number of moulding units can now be flexibly increased and decreased. The word "freely" refers to the capability to add or remove moulding unit(s) and not that the number of moulding units may be increased and decreased free of any cost and effort.

30 I agree with Tabata that the phrase "freely increasing/decreasing" simply means that the number of moulding units can be flexibly increased and decreased. The Patent does not contain any parameters on complexity, time or cost. In fact, Pecht himself observes that there is no metric to define what "freely" means. Consequently, it is not possible to read into Claim 4 (and, indeed, Claim 1) the limitations suggested by Pecht.

Number of moulding units and when number of moulding units adjusted

31 A third difference concerns, first, whether there can be infringement when there are only one or two moulding units involved in the allegedly infringing product or process. With regard to an allegedly infringing product, Pecht highlights that the disputed part of Claim 4 refers to "additional molding

units" (in the plural) being rendered detachably mountable with respect to an existing moulding unit. In his view, therefore, any apparatus that has only one or two moulding units will not infringe. As for an allegedly infringing process, Pecht highlights the reference to "an additional moulding unit" (in the singular) in Claim 1 to assert that any process that involves only one moulding unit in the apparatus will not infringe. In this respect, the relevant part of Claim 1 reads as follows:

A method of molding resin to seal electronic parts for sealing electronic parts being mounted on lead frames with a resin material through a molding unit (5) having a mold (26, 28), resin supply pots (29) being arranged in said mold, resin pressurizing plungers being provided on said pots, cavities being provided in mold surfaces of said mold, and resin passages being provided between said cavities and said pots, said method comprising:

a step of adjusting the number of molding units by detachably mounting an additional molding unit (5a, 5b, 5c) with respect to said molding unit (5) being already provided in an apparatus for molding resin to seal electronic parts;

...

32 In my view, Pecht's interpretation of Claims 1 and 4 is incorrect. As I have found earlier, the invention in Claim 4 concerns the application of the concept of modularity to the moulding units of moulding machines (see [22] above). This being the case, the actual number of moulding units involved is irrelevant, as the whole point is that this number is supposed to be flexible. Rather, what matters is whether the allegedly infringing product or process involves the *feature* of modularity.

33 Even if the number of moulding units were relevant, I reject Pecht's interpretation because it is precisely the kind of interpretation that the purposive approach to claim construction seeks to avoid, *ie*, "the kind of meticulous verbal analysis in which lawyers are too often tempted by their training to indulge" (see [20] above). The sense that one gets from reading the Patent is that any allegedly infringing product or process involving, at the very least, one to three additional moulding units would fall within Claims 1 and 4. This much is clear from how, in *both* Claims 1 and 4, the reference to "additional moulding units" (in Claim 4) and "an additional moulding unit" (in Claim 1) is followed by a reference to *three* additional moulding units, *viz*, "(5a, 5b, 5c)".

34 A second, related, point made by the defendants concerns the point in time when the number of moulding units is adjusted. The defendants' submission is to the effect that, because of the use of the past tense (*ie*, "rendered") in Claim 4, the Claim 4 apparatus does not require the actual addition or removal of any moulding unit, as long as a machine is provided with moulding units that are "detachably mountable". In contrast, however, the Claim 1 process requires the active step of "adjusting the number of molding units".

35 This submission relies on a literal interpretation of Claim 1 without consideration of its context. On any reasonable reading of Claim 1, it is obvious that the reference to "a step of adjusting the number of molding units", when read purposively, is a reference to the feature of modularity. On my part, it is patently clear that this part of Claim 1 is intended to correspond to the disputed part of Claim 4 (see [15] above). Claim 4, to reiterate, concerns the application of the concept of modularity to the moulding units of moulding machines (see [22] above). Consequently, this part of Claim 1 must be given a corresponding interpretation. I further note that the Patent was translated from Japanese. Accordingly, the court should be slow to give it an interpretation that is too literal.

Configurability of number of moulding units during manufacturing stage

36 A fourth difference between the parties has to do with whether Claim 4 covers moulding machines for which the number of moulding units can be configured during the manufacturing stage. Pecht appears to be of the opinion that it does. Tabata, on the other hand, disagrees and opines that the Patent clearly describes a moulding machine that is already built. In my judgment, Tabata is correct. In Claim 4 (and indeed in Claim 1 as well), there is a "molding unit (5)" which is described as being "already provided". This indicates that the contemplated adjustment of the number of moulding units is one that takes place *post-manufacture* and does *not* extend to the configurability of the number of moulding units during the manufacturing stage. Moreover, I agree with Tabata that various extracts from the Patent clearly state that the object of the invention is a moulding machine which can respond to changes in production needs by increasing and decreasing the number of moulding units, and that this is a feature that can exist only in a moulding machine that is already built. Indeed, there are references in the Patent to the number of moulding units being adjusted "in response to the production quantity as required" and "in response to the required production quantity".

Is the Patent (in particular, Claim 4) valid?

37 Having construed the Patent claims, I now consider the second broad issue, *viz*, is the Patent (in particular, Claim 4) valid? A number of sub-issues arise in relation to this broad issue:

- (a) Is the invention in Claim 4 novel?
- (b) Does the invention in Claim 4 involve an inventive step?
- (c) Does the Patent satisfy the sufficiency requirement?

Is the invention in Claim 4 novel?

The law

38 The requirement of novelty is prescribed by s 13(1) of the Patents Act. Section 14(1) of the Patents Act then states that an invention shall be taken to be new if it does not form part of the state of the art. It has been observed that the novelty inquiry involves two steps: (a) identify all the relevant pieces of "prior art" for the invention in question; and (b) assess whether the invention has been anticipated by any of these pieces of prior art (Ng-Loy Wee Loon, *Law of Intellectual Property of Singapore* (Sweet & Maxwell, 2nd Ed, 2014) at para 30.1.25).

39 In the present case, it is the second step that is principally in issue. In this connection, the Court of Appeal in *Mühlbauer AG v Manufacturing Integration Technology Ltd* [2010] 2 SLR 724 ("*Mühlbauer*") summarised (at [17]) the general test as follows:

...

In other words, in seeking to establish anticipation for the purposes of discounting (or even ruling out altogether) novelty, the directions contained in a prior publication (which constitutes part of the state of the art) *must be so clear that following those directions must inevitably lead to something that would, if the patentee's patent were valid, infringe the patentee's claim*. ... It has further been held in [*Genelabs Diagnostics Pte Ltd v Institut Pasteur and another* [2000] 3 SLR(R) 530] that the prior publication must "not only identify the subject matter of the claim in the later patent" ... but must also be an "enabling disclosure" (at [24]). This means that an invention "would be anticipated by a piece of prior art if the teachings disclosed in this prior art are

sufficiently clear and complete to allow the skilled addressee to make the invention ... [original emphasis omitted; emphasis added in italics]

40 The invention must be compared against each individual piece of prior art; generally speaking, it is not permissible to assemble all the pieces of prior art together into a "mosaic", and then to compare the invention under question against this "mosaic" (*Mühlbauer* at [68]). The prior art documents must be construed as if the court had to construe it at the date of publication and an *ex post facto* analysis is not appropriate (*Trek Technology (Singapore) Pte Ltd v FE Global Electronics Pte Ltd and others and other suits* [2005] 3 SLR(R) 389 ("*Trek*") at [87] affirmed in *Mühlbauer* at [18]). The burden of proving anticipation rests on the defendant (*Main-Line Corporate Holdings Ltd v United Overseas Bank Ltd and another (First Currency Choice Pte Ltd, third party)* [2007] 1 SLR(R) 1021 at [53]).

41 The above principles are well established. Notwithstanding, the defendants have urged me to consider two other defences, which are referred to as the *Gillette* defence and the "squeeze" argument respectively.

42 The *Gillette* defence stems from the decision of the House of Lords in *Gillette Safety Razor Company v Anglo-American Trading Company Ltd* (1913) 30 RPC 465 ("*Gillette Safety Razor*"), which concerned an action for patent infringement. Lord Moulton considered a piece of prior art ("*Butler*") and concluded (at 480–481):

... I am of opinion, therefore, that there is no patentable difference between the Defendants' safety razor and that shown and described by *Butler*. ... It follows, therefore, that no Patent of date subsequent to the publication of *Butler's* Specification could possibly interfere with the right of the public to to [*sic*] make the Defendants' razor. If the claims of such a Patent were so wide as to include it, the Patent would be bad, because it would include something which differed by no patentable difference from that which was already in possession of the public. Such a Patent would be bad for want of novelty. If the Claims were not sufficiently wide to include the Defendants' razor, the patentee could not complain of the public making it. In other words, the Defendants must succeed either on invalidity or on non-infringement.

... It is impossible for an ordinary member of the public to keep watch on all the numerous Patents which are taken out and to ascertain the validity and scope of their claims. But he is entitled to feel secure if he knows that that which he is doing differs from that which has been done of old only in non-patentable variations, such as the substitution of mechanical equivalents or changes of material shape or size. The defence that "the alleged infringement was not novel at the date of the plaintiff's Letters Patent" is a good defence in law, and it would sometimes obviate the great length and expense of Patent cases if the defendant could and would put forth his case in this form, and thus spare himself the trouble of demonstrating on which horn of the well-known dilemma the plaintiff has impaled himself, invalidity or non-infringement.

43 The "squeeze" argument, on the other hand, is a variation of the *Gillette* defence. The defendants refer me to an earlier edition of the *CIPA Guide to the Patents Act* (Sweet & Maxwell, 7th Ed, 2011), where it is stated (at para 125.17) that the "squeeze" argument "particularly arises when there is the possibility of an elastic interpretation of a claim so that a defendant can contend that a claim will be either invalid if construed broadly, or not infringed if construed more narrowly".

44 It seems to me that neither the *Gillette* defence nor the "squeeze" argument departs from the well-established principles of the law of Patents. Rather, their identifying feature is that they allow a court to come to a conclusion on liability without actually having to construe the claim(s) in question

(see *Gillette Safety Razor* at 480; *CIPA Guide to the Patents Act* at para 125.17). As I have already construed the Patent claims (in particular, Claim 4) earlier in this judgment, a consideration of the *Gillette* defence or the “squeeze” argument is neither necessary nor profitable in the present case. I observe, however, that it may not be ideal for courts to side-step the issue of claim construction altogether. Indeed, Lord Moulton in *Gillette Safety Razor* accepted (at 480) that “such a mode of deciding a Patent case is unusual”.

Analysis

45 Having set out the applicable legal principles, I now consider the relevant prior art. Parties have agreed that there are three pieces of prior art that fall for my consideration: (a) a Japanese patent filed by Kyuushuu NEC Co Ltd (“NEC”); (b) a Japanese patent filed by Hitachi, Ltd (“Hitachi”) and (c) a machine made by Advanced Systems Automation Pte Ltd (“ASA”) known as the ASA 808K (“ASA 808K”). These will be considered in turn.

(1) NEC

46 The first piece of prior art is NEC, which deals with an invention titled “Resin Sealing Device for Semiconductor”. I am of the view that NEC does not anticipate the invention in Claim 4 because the machine in NEC does not contemplate modularity of moulding units.

47 Figure 1 of NEC shows that the moulding units of the machine in NEC are attached to what appears to be a table top of fixed dimensions:

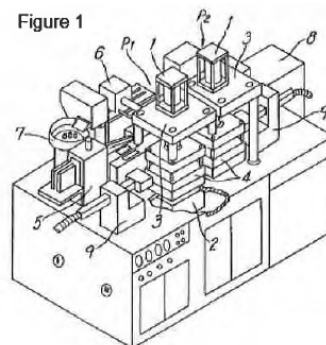

I agree with Tabata that having the moulding units connected to a table top is a clear indication that the moulding machine in NEC is not designed to be modular and that the moulding units are not designed to be removed or added. Tabata states that any detachment of the moulding units would not be feasible as it would leave a gap in the machine, likely rendering the machine inoperable. In response to this, Pecht opines that any gap “can be handled by the robotics”. However, even if I were to accept Pecht’s evidence on this point, this only deals with the detachment or removal of moulding units. In so far as the addition of moulding units is concerned, Tabata’s view, which I find difficult to refute, is that any addition of moulding units would be impossible as there is no space to do so.

48 Admittedly, there are passages in NEC which allude to the number of moulding units being changeable. At one point, it is stated that “[t]his invention can be attached with a multiple number of press structure”. At another, it is stated that “[t]his invention is not limited to above implementation example, the transfer mold press and mold number can be increased, and with this it surround automotive units arrangement can be changed without being said”. In light of Figure 1, however, the only possible interpretation of these passages is that they refer to the number of moulding units being configurable during the manufacturing stage. In other words, a customer can place an order for a

moulding machine with a variable number of moulding units. However, as alluded to at [36] above, this is not the same as the adjustability of the number of moulding units *post-manufacture*, which is what is contemplated by Claim 4. NEC, therefore, does not anticipate the invention in Claim 4.

(2) Hitachi

49 The second piece of prior art is Hitachi, which concerns an invention named "Molding system". In my view, Hitachi does not anticipate the invention in Claim 4 because the machine in Hitachi does not contemplate modularity of moulding units. It is to be recalled that the burden of proving anticipation falls on the defendants in the present case (see [40] above). In this regard, Pecht's evidence on Hitachi is unsatisfactory.

50 Pecht relies on, *inter alia*, the following passages in Hitachi:

Also, each Mold 11 ~ 16 has either the same type or different type of mold placed at equal pitches in a straight series; the molds can be exchanged at one's discretion. ...

...

... there are multiple small molds which are placed one next to the other. Even if one cavity deteriorates in quality, only the mold needs to be exchanged and there is no need to stop the manufacturing process as it is possible to continue the molding process with the other molds. In addition, as it is only necessary to change the had [*sic*] mold, and the mold is a small mold, the operation of exchange is very simple.

In his report, Pecht originally opined that the word "mold" in Hitachi "clearly corresponds" to the moulding unit in the Patent. At trial, however, Pecht accepted that the word "mold" is used "in many different ways" in Hitachi.

51 On the other hand, the plaintiff submits that the above passages refer to exchangeability of the mould and not the moulding unit. According to Tabata, the mould is only a subset of the moulding unit, which comprises both the mould and the pressing mechanism. The purpose of changing moulds is to replace those which have worn out cavities or to react to different manufacturing requirements (*eg*, when different integrated circuits need to be moulded in a different form). In contrast, the purpose of adding or removing moulding units is to react to different levels of production capacities.

52 It seems to me that the above passages in Hitachi have to do with exchangeability of moulds rather than moulding units. In the first passage, it is undisputed that "Mold 11 ~ 16" refers to the moulding unit. This being the case, the second reference to "mold" must logically refer to a mould rather than a moulding unit. This is the only sensible reading of the passage; otherwise, the passage would illogically suggest that each moulding unit has either the same or different type of moulding unit. As for the third reference to "molds" (which has to do with exchangeability), it is quite clear from the context that this has the same meaning as the second reference to "mold". As for the second passage, the reference to a cavity deteriorating in quality indicates that what is being discussed is the exchangeability of moulds rather than moulding units. Indeed, it would be excessive to replace the entire moulding unit just to rectify a deteriorating cavity.

53 Even if Hitachi had to do with the exchangeability of moulding units, I find merit in the plaintiff's submission that the concept of exchanging is not the same as that of adding and removing moulding units to react to different production volumes as there is no change in the number of moulding units in the former scenario. Admittedly, the second passage in Hitachi referred to above does contemplate

that in the process of exchange, there may be a period of time whereby the moulding unit (on the assumption that this is what "mold" refers to) that is being exchanged is not working. In substance, this is no different from a scenario where a moulding unit is being removed. However, this still leaves the addition of a moulding unit unaccounted for. In this connection, I am not persuaded by Pecht's argument, which appears to be that moulding units can be added on the basis that: (a) the machine in Hitachi does not have a common base but is mounted on the ground; and (b) the robotic track is extendable and the software can be programmed accordingly. Quite apart from the bare nature of these assertions, nowhere in Hitachi is it mentioned that a "mold" can be added. Pecht had in fact conceded at trial that Hitachi does not expressly mention that a moulding unit can be added.

54 A final point on Hitachi relates to the following passage in Hitachi:

We have given explanation as per above on the invention created by the inventors, specifically based on an actual execution sample. However, it goes without saying that the execution is not limited to the said sample and many modifications can be made as long as the content is not out of scope. For example, as long as the robot can move back and forth, there is no need for rails.

Also, the Cleaning Section, Loading Section, Unloading Section, Inserting Section can each be positioned at its own station and have the sections each work on an individual mold. *Of course, the pressing structure and each specific structure of the robot can be changed accordingly.* If there is ample space, molds can be placed on both sides of the robot. Inversely, the robot can also rotate around the mold.

[emphasis added]

Pecht relies on the emphasised part of the above passage. However, the furthest this passage goes is to suggest that the number of moulding units can be configured during the manufacturing stage. However, as alluded to at [36] above, this is not the same as the adjustability of the number of moulding units *post-manufacture*, which is what is contemplated by Claim 4. Hitachi, therefore, also does not anticipate the invention in Claim 4.

(3) ASA 808K

55 The final piece of prior art is the ASA 808K. A preliminary point that needs to be dealt with is the plaintiff's submission that there is no evidence of prior sale and use of the ASA 808K before 22 July 1993, the priority date of the Patent. This submission goes towards the first step in the novelty inquiry (see [38] above). There is, however, no need for me to consider the substantive merits of this submission as the parties' experts' joint statement already indicates that parties are in agreement that the ASA 808K forms part of the relevant prior art. In these premises, the plaintiff would be hard-pressed to maintain this submission, which was, rightfully, not pursued much in oral submissions.

56 In any event, I am of the view that the ASA 808K also does not anticipate the invention in Claim 4 because the ASA 808K does not contemplate modularity of moulding units. First, the ASA 808K is a four-moulding unit machine with a base plate which is custom-built for four moulding units. That the ASA 808K comes with four moulding units is evident from the ASA 808K's manual. In fact, Ng Wee Huat ("Wee Huat"), the first defendant's senior technical consultant, gave evidence that the last "8" in "ASA 808K" is indicative that the four-press machine can mould up to eight lead frames simultaneously; a three-press machine has the name "ASA 806K" and so on. As for the customised size of the base plate, the defendants' witnesses' evidence is that if the number of moulding units needed to be increased, the base plate would need to be changed. All this being the case, I am

unable to see how the ASA 808K can have modular moulding units. As Tabata has observed, where moulding units are connected to a common platform instead of each other, the addition of moulding units would be impossible as there is no space to do so.

57 Second, any “modularity” contemplated by the ASA 808K has, at its highest, to do with continuity of production when one moulding unit is removed or breaks down. It does not involve flexibility in terms of adjusting (and especially increasing) production capacity. In this regard, Wee Huat testified at trial that sometime in 1991, his company ordered an ASA 808K but, as ASA was short of one moulding unit and his company was in urgent need of the machine, the ASA 808K was shipped with only three moulding units and the fourth moulding unit was only installed subsequently. Another of the defendants’ witnesses, Ng See Hwee, gave evidence at trial that, sometime in the later half of 1990, he had seen the ASA 808K operating with one moulding unit removed for repair during the “pre-buy-off” process (which I understand to be part of the testing process) at ASA’s factory. Both of these instances of “modularity” do not actually involve any addition in the number of moulding units. Rather, all they show is that the ASA 808K is capable of operating even when one moulding unit is absent.

58 Neither am I persuaded by Pecht’s reliance on passages in the ASA 808K’s manual which, at first blush, give the impression that the ASA 808K contemplates modularity of moulding units. The first such passage reads: “[m]odular design permits flexibility and interchangeability to accept a wide range of package configurations”. Tabata, however, explains that the modularity mentioned in the ASA 808K’s manual refers to the ease of exchanging the mould and the plunger in order to service different types of product packages. The second passage in the ASA 808K’s manual relied on by Pecht states as follows:

Each press is a unit by itself with its own four support columns, top and bottom platens, and mold transfer mechanism. This ensures even clamping profile of each mold without interference from the adjacent molds. Each press has its individual control system so that should any one mold needs [*sic*] to be serviced, the rest can still operate.

In my judgment, this passage is simply referring to the use of software (*ie*, the “individual control system”) to disable (and presumably also enable) any given moulding unit on the ASA 808K. Plainly, this is entirely different from the *physical* modularity of moulding units contemplated by Claim 4.

59 Finally, I should also state that I give no weight to the photographs adduced by the defendants showing what appears to be a moulding unit removed from a similar machine known as the ASA 808S. The ASA 808S is not relied on as prior art by the defendants. In any event, the photographs do not assist the defendants’ case on any front, as all they show is the removal of a moulding unit from the ASA 808S. The ASA 808K, therefore, also does not anticipate the invention in Claim 4. Accordingly, the invention in Claim 4 is novel.

Does the invention in Claim 4 involve an inventive step?

The law

60 The requirement of inventive step is likewise prescribed by s 13(1) of the Patents Act. Section 15 of the Patents Act then states that an invention shall be taken to involve an inventive step if it is not obvious to a person skilled in the art, having regard to any matter which forms part of the state of the art by virtue only of s 14(2) of the Patents Act and without having regard to s 14(3) of the same. Like the novelty inquiry, the inventive step inquiry also involves two steps: (a) construct the relevant state of the art for the invention in question; and (b) compare the invention with the state

of the art to determine if the invention is obvious to the person skilled in the art (*Law of Intellectual Property of Singapore* at para 30.1.46).

61 In so far as the second step is concerned, the Court of Appeal has repeatedly affirmed the four-step approach set out in *Windsurfing International Inc v Tabur Marine (Great Britain) Ltd* [1985] RPC 59 ("*Windsurfing*") (at 73–74) (see, for example, *Mühlbauer* at [20]; *Merck & Co Inc v Pharmaforte Singapore Pte Ltd* [2000] 2 SLR(R) 708 at [50]). The four steps to this approach are as follows:

- (a) Identify the inventive concept embodied in the patent in suit.
- (b) Assume the mantle of the normally skilled but unimaginative addressee in the art at the priority date and impute to him what was, at that date, common general knowledge in the art in question.
- (c) Identify what, if any, differences exist between the matter being cited as being known or used and the alleged invention.
- (d) Ask whether, viewed without any knowledge of the alleged invention, those differences constitute steps which would have been obvious to the skilled man or whether they require any degree of invention.

62 The burden of proof is upon the defendant to show that no inventive step was involved (*Mühlbauer* at [19]; *Ng Kok Cheng v Chua Say Tiong* [2001] 2 SLR(R) 326 ("*Ng Kok Cheng*") at [16]–[17]). In *First Currency Choice*, the Court of Appeal observed (at [44]) that it is the fourth step of the *Windsurfing* approach that is "ultimately the only critical question". In this fourth step, and unlike in the novelty inquiry, it is permissible to construct a "mosaic" out of the various pieces of prior art, unless the act of "mosaicing" itself is not obvious to the notional skilled person (*Mühlbauer* at [93]). Moreover, simplicity is no bar to inventiveness (*Mühlbauer* at [102]) and a small step can still be an inventive step (*Peng Lian Trading Co v Contour Optik Inc and others* [2003] 2 SLR(R) 560 at [28]).

Analysis

63 Although the defendants originally pleaded that the Patent did not involve an inventive step, this issue is not dealt with in any substantive measure in the defendants' closing submissions. It is only in their reply submissions that the defendants seek to deal with this issue and "show that the Patent is obvious". Even then, however, all the defendants do is attempt to rebut the plaintiff's submissions. In both sets of submissions, there is no mention of the well-established *Windsurfing* approach, much less an engagement of its four steps. Fatally, there is no meaningful attempt to compare the invention in Claim 4 with the prior art and show how and why the differences (if any) are obvious to a person skilled in the art. The defendants' submissions on the issue of inventive step are therefore woefully inadequate to discharge their burden of proof.

64 Interestingly, Pecht did deal with the issue of inventive step in his report. However, in light of the defendants' submissions, it is not entirely clear if Pecht's opinion on this issue has been adopted by the defendants. In any event, Pecht's opinion that there is no inventive step is based on his view that there is no difference between what is known or used and the alleged invention. As the plaintiff submits, therefore, Pecht's opinion really is that the invention in Claim 4 does not involve an inventive step only because it is anticipated by the three pieces of prior art. Given my findings on the novelty issue, Pecht's opinion on the inventive step issue also does not assist the defendants, even if the defendants had intended to rely on it. Accordingly, the invention in Claim 4 involves an inventive step.

Does the Patent satisfy the sufficiency requirement?

The law

65 The sufficiency requirement is also known as the “enabling disclosure” requirement (*Law of Intellectual Property of Singapore* at para 30.2.1). Under s 80(1)(c) of the Patents Act, a patent may be revoked if its specification “does not disclose the invention clearly and completely for it to be performed by a person skilled in the art”. The burden of proving insufficiency rests on the defendant challenging the validity of a registered patent (*Ng Kok Cheng* at [48]). In determining whether the specification of a patent is sufficient, a two-step test applies: (a) identify the invention and decide what it claims to enable the skilled man to do; and (b) ask whether the specification enables him to do it (*First Currency Choice* at [61] following *Kirin-Amgen Inc v Hoechst Marion Roussel Ltd* [2005] RPC 9 at [103]).

66 In the present case, the first step has already been addressed (see [18]–[36] above) and it is therefore the second step that remains in issue. In this regard, whether the patent specification discloses the invention clearly enough and completely enough for it to be performed by a person skilled in the art is a question of degree, and the question of the sufficiency of the disclosure would be a matter of fact, depending on the nature of the invention and the other circumstances of the case (*First Currency Choice* at [60]). However, it must be borne in mind that the phrase “clearly and completely” contemplates that the patent specification need not set out every detail necessary for the performance of the invention, but can leave the skilled man to use his skill to perform the invention (*First Currency Choice* at [60]). In *Mentor Corporation and Another v Hollister Incorporated* [1993] RPC 7, the English Court of Appeal held (at 10) that:

... Disclosure of an invention does not have to be complete in every detail, so that anyone, whether skilled or not, can perform it. Since the specification is addressed to the skilled man, it is sufficient if the addressee can understand the invention as described, and can then perform it. In performing the invention *the skilled man does not have to be told what is self-evident, or what is part of common general knowledge*, that is to say, what is known to persons versed in the art. ... [emphasis added]

67 In addition, regard should also be given to the following two “further considerations” highlighted by the Court of Appeal in *First Currency Choice* (at [62]):

... First, the specification of the patent must embrace an embodiment of the invention asserted in each of the claims with sufficient particularity to enable the invention to be understood and carried into effect by those in the industry without making further inventions or prolonged study of the matter. The specification must be set out clearly and fairly so that any individual desirous of carrying out the invention may obtain full knowledge of its practical aspects. But, it is not necessary that the specification be so detailed that this notional individual can perform the invention without any trial or experiment at all. Second, the description of the invention should not be unnecessarily difficult to follow, and must not contain any traps or seriously misleading statements which the reader cannot correct ...

Analysis

68 As stated, the first step of the two-step test has already been addressed: the invention in Claim 4, broadly speaking, is the application of the concept of modularity to the moulding units of moulding machines (see [22] above). It is therefore the second step that remains in issue, and the question to be answered is whether the patent specification discloses this invention clearly and

completely for it to be performed by a person skilled in the art.

69 I start by looking at the Patent. In this regard, and in so far as the modularity of moulding units is concerned, two paragraphs and two figures in the Patent are relevant. The two paragraphs read as follows:

The engaging means 38 is provided between the molding unit 5 of the apparatus for molding resin to seal electronic parts which is formed by the combination of the minimum units shown in Figs. 1A and 1B and the additional molding unit 5a which is coupled with or detached from the same, for simply and reliably positioning the molding units 5 and 5a and coupling the same with each other.

The engaging means 38 may be formed by irregular engaging parts which are formed on bottom bases 39 of the molding units 5 and 5a as shown in Figs. 3 and 7, for example.

As for the figures, the first relevant figure is Figure 3:

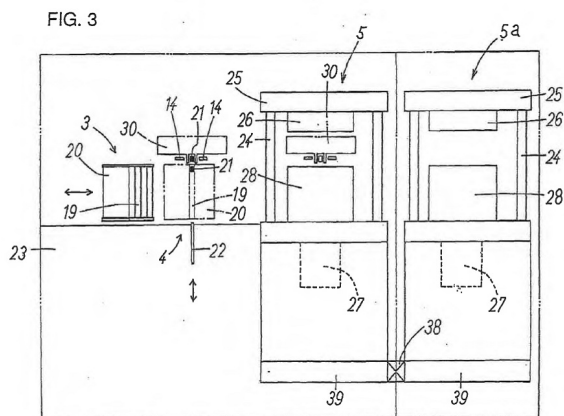

The other relevant figure is Figure 7:

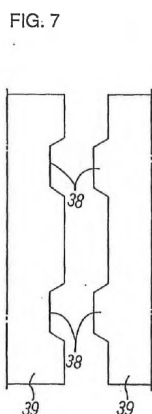

70 The crux of the issue is whether the above references to “engaging means 38” are sufficient to allow a person skilled in the art to achieve modularity of moulding units in moulding machines. In this respect, Tabata accepts that Figure 7 provides an illustration of such engaging means without specifying what such means are. However, Tabata asserts that a person skilled in the art would know that:

- (a) The *alignment* of moulding units in moulding machines can be achieved through the use of

alignment bars, guiding pins and fitting holes. These methods and devices are commonplace for automation machines where the precise alignment of the various components/parts of the machine is always necessary to ensure that the automation process can be carried out smoothly. At the date of the Patent, there were also already automated moulding machines with multiple moulding units in the market (eg, the ASA 808K). Persons familiar with such machines would know how the different components need to be aligned for the machine to operate properly.

(b) To *connect* two moulding units together (with the intention of possible subsequent disconnection), such connection can be easily achieved through the use of nuts/bolts, connecting screws *etc.* These methods and devices would have been obvious and commonplace to even a lay person, much less a person familiar with machinery.

In these premises, Tabata opines that it was not necessary to stipulate in the Patent what the “engaging means” refer to. Any person familiar with automated moulding machines reading the specification of the Patent as at the date of the Patent would be aware of the methods and devices that make up these “engaging means”, and need not require further specification to be able to perform the invention in the Patent.

71 If unrebutted, Tabata’s evidence would be sufficient to establish that the Patent satisfies the sufficiency requirement. It is to be recalled that there is no need for the patent specification to set out every detail necessary for the performance of the invention as the skilled man (who does not have to be told what is self-evident, or what is part of common general knowledge) can be left to use his skill to perform the invention (see [66] above). With this in mind, I turn to consider Pecht’s evidence.

72 As I understand them, Pecht’s views are as follows. First, Pecht argues that there is no enabling disclosure in the Patent as to what the “simple means” (referred to elsewhere in the Patent) comprises. This point harks back to Pecht’s view that Claim 4 excludes machines which require complex and time-consuming attachment/detachment and positioning operations to be performed when increasing/decreasing the number of moulding units (see [29] above). What I understand Pecht to be saying, therefore, is that the Patent does not show how a moulding unit can be “simply” added or removed. However, as I have earlier found that the “simple” addition or removal of a moulding unit is not part of the invention of Claim 4 (see [30] above), it follows that Pecht’s first point on the issue of sufficiency cannot hold water.

73 Second, Pecht opines that the skilled addressee would know that precise alignment needs to be achieved to make a moulding system functional and reliable. However, there is no enabling disclosure which teaches how precise alignment is to be achieved, notwithstanding the references to “engaging means 38” and Figure 7. Pecht therefore disagrees with Tabata’s view as set out at [70(a)] above. He further asserts that Tabata appears to make reference to common general knowledge, but that no support is given. Parenthetically, I note that Pecht does not dispute Tabata’s view as set out at [70(b)] above and this much was confirmed at trial.

74 However, the fatal flaw in this aspect of Pecht’s evidence is that Pecht does not explain *why* a person skilled in the art looking at the Patent would *not* know how the requisite alignment is to be achieved. Pecht’s evidence is therefore nothing more than a bare and unexplained denial of Tabata’s position. Consequently, Tabata’s position is left unrebutted. Moreover, Pecht’s allegation that Tabata has not supported his reference to common general knowledge does not assist the defendants because the burden of proving insufficiency in the present case rests, not on the plaintiff, but on the defendants (see [65] above). Pecht’s allegation is also rather ironic because Pecht has not even proffered reasons (much less evidence) for his view. In contrast, Tabata has, at the very least, set

out the reasons for his position.

75 I therefore find that the Patent satisfies the sufficiency requirement. As the defendants have failed to establish a lack of novelty, inventive step or sufficiency, the Patent (in particular, Claim 4) is, accordingly, valid.

Are the defendants *prima facie* liable for infringing the Patent?

76 As the Patent is valid, the next broad issue is whether the defendants are *prima facie* liable for infringing the Patent. In making this determination, two sub-issues fall for my consideration:

(a) Does the IDEALmold machine fall within the scope of the Patent claims?

(b) If the IDEALmold machine falls within the scope of the Patent claims, have the defendants committed any infringing acts in relation to the IDEALmold machine?

Does the IDEALmold machine fall within the scope of the Patent claims?

Retrofitting

77 Having already construed the Patent claims (see [18]–[36] above), the answer to the first sub-issue turns primarily on a process known as retrofitting. The defendants do not dispute that retrofitting does in fact allow for an increase and decrease in the number of moulding units on the IDEALmold machine. It is also not disputed that retrofitting was offered as a service to customers who asked for and agreed to pay for it (although, to be fair, the evidence on this point was, strictly speaking, given in the context of retrofitting to add a moulding unit). Retrofitting has in fact been successfully carried out to add moulding units to IDEALmold machines. There has not been any request to remove moulding units; this is because a moulding unit which was not required could simply be deactivated *via* the software of the IDEALmold machine. On my part, it is clear that modularity of moulding units was envisaged as a feature of the IDEALmold machine and that retrofitting provided for this. The IDEALmold machine, having the feature of modularity of moulding units, therefore falls squarely within the Patent claims.

78 The defendants, however, make two main points with regard to retrofitting. First, they argue that retrofitting has not been pleaded. Second, they submit that retrofitting is complex, costly and time-consuming. In my view, both of these contentions are without merit.

79 With respect to the defendants' first point, the argument goes that as retrofitting has not been pleaded, no evidence of it can be given. Reliance is placed on O 87A r 7(1) of the Rules of Court. It is not entirely clear which edition of the Rules of Court the defendants are relying on (the Suit was commenced in 2013). For the sake of convenience, I shall simply refer to the Rules of Court (Cap 322, R5, 2014 Rev Ed) ("ROC"). In this regard, O 87A r 7(1) of the ROC provides as follows:

7.—(1) Except with the leave of the Court, no evidence shall be given of any alleged infringement, or of any objection to the validity, of the patent, if the infringement or objection was not raised in the particulars of infringements or objections, as the case may be.

80 In response, the plaintiff refers to O 87A r 2(2) of the ROC, which states as follows:

(2) The plaintiff in such an action must serve with his statement of claim particulars of the infringement relied on, showing which of the claims in the specification of the patent are alleged

to be infringed and giving at least one instance of each type of infringement alleged.

The plaintiff submits that it has met its obligation: it has identified the IDEALmold machine as the infringing machine, specified the claims in the Patent which the IDEALmold machine infringes, described the infringing acts and provided examples of such acts.

81 In my view, the defendants' objection is entirely misconceived. Retrofitting is nothing more than a means which provides for the modularity of the moulding units of the IDEALmold machine. Critically, retrofitting is *not* the alleged infringement. Indeed, retrofitting *cannot* be the alleged infringement because the Patent does not concern the means by which modularity is achieved. Rather, the alleged infringement has to do with the IDEALmold machine which has the *feature* of modularity and it is sufficient if the plaintiff has pleaded that the IDEALmold machine infringes the Patent. In this respect, the plaintiff's Particulars of Infringement (Amendment No 1) clearly makes reference to the IDEALmold machine as the alleged infringement. There is no need for the plaintiff to further identify the means by which modularity is achieved as this is largely irrelevant.

82 This analysis (*ie*, that the alleged infringement is not retrofitting *per se*) also suffices to deal with the following ancillary submissions of the defendants concerning retrofitting:

(a) That an offer to retrofit or even the act of retrofitting does not fall under any of the pleaded acts of infringement. With respect to Claims 1 and 2 (the process claims), the point seems to be that the retrofitted IDEALmold machine is always operated by the customer, whereas for Claims 4 and 5 (the product claims), the argument appears to be that the IDEALmold machine already belongs to the customer by the time of retrofitting.

(b) That there is no pleading or allegation that retrofitting has been performed in Singapore.

(c) That the IDEALmold machine is not infringing *per se*, but only potentially infringing if retrofitting is carried out.

All these submissions are premised on the misconception that retrofitting *per se* is the alleged infringement. To reiterate, retrofitting is *not* the alleged infringement. Rather, the alleged infringement has to do with the IDEALmold machine which has the *feature* of modularity.

83 The defendants' second point concerning retrofitting is that retrofitting is complex, costly and time-consuming. The argument seems to be that, therefore, the IDEALmold machine falls outside the scope of the Patent claims.

84 The defendants go to great lengths to make this point. Wee Kock Hien ("Wee"), the first defendant's technical manager, stated as follows in his affidavit of evidence-in-chief ("AEIC"):

... However, while the 1st Defendant offers such a retrofit service to customers that ask for and agree to pay for it, the 1st Defendant does not encourage retrofitting since it requires disassembling and then retrofitting the IDEALmold system with new parts, such as parts specifically required for catering to any new molding presses. Many of the existing components will no longer be usable for the new retrofitted system and have to be discarded. A lot of work at a significant price to the customer has to go into retrofitting because the IDEALmold was not designed to facilitate the attachment of further molding presses to an assembled IDEALmold system. ...

Wee then goes on to describe the 25 steps purportedly involved in the adding of a fourth moulding

press to a three-moulding unit IDEALmold machine before concluding, at step 26, as follows:

In summary, adding a molding press requires making many significant material changes, calibration and software updates, and requires the use of specialized and heavy equipment, including alignment tools and mobile lifter trucks. The process will require two trained engineers about one week to complete.

In a similar vein, Pecht, referring to Wee's AEIC, opines that "no molding unit can be added or removed without complex rebuilding, replacement of multiple operational parts, custom alignment and software changes".

85 This point is clearly premised on Pecht's view that Claim 4 only covers machines which can have their number of moulding units adjusted easily, cheaply and quickly (see [29] above). However, as I have already rejected this proposition (see [30] above), this point cannot pass muster. Put simply, the Patent claims cover machines which have the feature of modularity and it is irrelevant that this modularity is achieved through means which are complex, costly and time-consuming.

86 In any event, I am of the view that retrofitting is not as complex, costly and time-consuming as the defendants make it out to be. First, and as I have already stated (see [77] above), retrofitting was offered as a service to customers. The plaintiff submits, and I fully agree, that it is inconceivable that such a service would have been offered if retrofitting were truly so complex, costly and time-consuming.

87 Second, I am inclined to agree with the plaintiff's submission that it is only the accessorial and peripheral cables, belts, tracks and wirings *etc* that need to be replaced during retrofitting. These parts were of fixed dimensions, depending on the number of moulding units. At trial, Wee testified that the onloader and offloader remained unchanged. The onloader is the component of the IDEALmold machine that picks up the lead frame and pellet and feeds them into the moulding unit, whereas the offloader serves the converse function after the moulding is done. In my view, these are the key components of the IDEALmold machine and the fact that they remain unchanged during retrofitting is telling.

88 Third, in so far as costs are concerned, the evidence is that retrofitting to add an additional unit is still cheaper than purchasing an additional one-moulding unit machine. There was evidence at trial that a customer who retrofitted a particular make of a three-moulding unit IDEALmold machine to add an additional moulding unit would need to spend around US\$250,000. In contrast, the purchase of an additional one-moulding unit IDEALmold machine would cost US\$413,000. Thus, in this particular example, there would be cost savings of around US\$160,000.

89 Finally, I should also add that I am not impressed by Wee's testimony at trial that the amount of time taken for retrofitting (one week) is similar to the time taken to "configure" a new IDEALmold machine. Even if I were to accept Wee's evidence, retrofitting does not become time-consuming just because it takes the same amount of time as "configuring" a new IDEALmold machine.

90 In these circumstances, the IDEALmold machine, by virtue of its retrofitting feature, falls squarely within Claim 4 as well as Claim 5, which is dependent on Claim 4. As Claim 1 simply teaches the process whereby the moulding machine taught in Claim 4 is operated, the IDEALmold machine, in so far as its operation is concerned, also falls within Claim 1. Subject to what will be said in the following section (see [91]–[95] below), it also falls within Claim 2, which is dependent on Claim 1. It should be noted that, apart from the invention in Claim 4 (for which there is a corresponding part in Claim 1 (see [35] above)) as well as what will be said in the following section (see [91]–[95] below),

there is no dispute that the IDEALmold machine takes the remaining elements of Claims 1, 2, 4 and 5.

Double-storage step

91 A second string to the defendants' bow is the submission that the IDEALmold machine does not have the double-step storage purportedly referred to in Claim 2. This submission is based on the part of Claim 2 that reads as follows:

A method of molding resin to seal electronic parts in accordance with claim 1, wherein ...

...

said step of taking out said sealed electronic parts from each said molding unit (5, 5a, 5b, 5c) to the exterior includes:

...

a step of transferring said sealed lead frames passing through said step of removing said gate portions to a lead frame storage unit (12),

a step of picking up said sealed lead frames passing through said step of removing said gate portions in said lead frame storage unit (12) independently of each other, and

a step of storing said sealed lead frames being picked up independently of each other.

Reference is also made to the following part of the Patent:

... a step of picking up the sealed lead frames 14 from the position of the lead frame storage unit 12 by the pickup unit 11, and a step of storing the sealed lead frames 14 picked up by the pickup unit 11 in the stock magazines 37.

The argument is that there are two storage steps mentioned in Claim 2: one in "lead frame storage unit 12" and one in "stock magazines 37". In contrast, the IDEALmold machine does not have a double-storage step for the lead frames. Pecht's evidence is that "[a]fter the electronic parts are molded and the IDEALmold [machine] degates the parts, it drops (not picks) the molding lead frames parts into a single location (a stack magazine) which holds the [lead frames]".

92 In light of my finding at [90] above, it is not strictly necessary for me to make a finding on this issue of the double-storage step. Even if I were to find in favour of the defendants, the IDEALmold machine would still fall within Claims 1, 4 and 5. Notwithstanding, I am of the view that there is, in fact, no double-storage step referred to in Claim 2.

93 In this respect, I agree with the plaintiff's submission that Pecht has confused the first step of *transferring* sealed lead frames to "lead frame storage unit 12" to be a storage step in itself when, in this step, there is no actual storage. Rather, the actual storage is only done in the last step, when the sealed lead frames are stored in "stock magazines 37". There are two steps only because Claim 2 describes: (a) moving the sealed lead frames to "lead frame storage unit 12"; and (b) storing the sealed lead frames in "stock magazines 37" within "lead frame storage unit 12". The plaintiff further refers to the following paragraphs of the Patent:

The lead frame storage unit 12 is provided with stock magazines 37 capable of storing two sealed lead frames 14 which are independently picked up through the pickup mechanism 36 of the pickup

unit 11 independently of each other.

The two sealed lead frames 14 which are picked up by the pickup mechanism 36 of the pickup unit 11 independently of each other are relieved from the pickup mechanism 36 when the pallet 33 of the transfer unit 9 is retracted to its original position so that the same can be stored in the prescribed stock magazines 37 provided under the same independently of each other, as shown in Fig. 6D.

94 It seems to me that the sealed lead frames, after being transferred to "lead frame storage unit 12", are picked up by "pickup mechanism 36" before actually being stored in "stock magazines 37". In my judgment, it would be a literary strain to say that the *transfer* of sealed lead frames to "lead frame storage unit 12" is a step of *storage*. Storage, in the ordinary sense of the word, only occurs in "stock magazines 37". This interpretation is further supported by the fact that "stock magazines 37" are actually found within "lead frame storage unit 12" (see the part of the quote at [93] above which says that "lead frame storage unit 12 is provided with stock magazines 37"). It does not make sense to have two storage areas, one found within the other.

95 In these premises, I reject the plaintiff's submission concerning double-step storage. My findings at [90] above therefore remain unchanged: the IDEALmold machine falls within Claims 4 and 5 and, in so far as its operation is concerned, also falls within Claims 1 and 2.

Have the defendants committed any infringing acts in relation to the IDEALmold machine?

96 As the IDEALmold machine falls within the scope of the Patent claims, I now turn to consider whether the defendants have committed any infringing acts in relation to the IDEALmold machine. For present purposes, the relevant list of infringing acts is found in ss 66(1)(a) and (b) of the Patents Act, which state as follows:

66.—(1) Subject to the provisions of this Act, a person infringes a patent for an invention if, but only if, while the patent is in force, he does any of the following things in Singapore in relation to the invention without the consent of the proprietor of the patent:

(a) where the invention is a product, he makes, disposes of, offers to dispose of, uses or imports the product or keeps it whether for disposal or otherwise;

(b) where the invention is a process, he uses the process or he offers it for use in Singapore when he knows, or it is obvious to a reasonable person in the circumstances, that its use without the consent of the proprietor would be an infringement of the patent;

...

97 I have earlier set out the infringing acts which the plaintiffs plead the defendants have committed (see [9] above). For ease of reference, this is set out in tabular form as follows:

Pleaded infringing acts	
First defendant	Claims 1 and 2 (process claims)
	Offered for use

	Claims 4 and 5 (product claims)	Made Disposed of Offered to dispose of Kept
Second defendant	Claims 4 and 5 (product claims)	Made Kept
Both defendants (j o i n t tortfeasorship by common design)	Claims 1 and 2 (process claims)	Offered for use
	Claims 4 and 5 (product claims)	Made Disposed of Offered to dispose of Kept

First defendant

(1) Claims 4 and 5 (product claims)

98 I start by looking at the infringing acts alleged against the first defendant in relation to Claims 4 and 5. As these are product claims, the relevant provision is s 66(1)(a) of the Patents Act. There is little dispute over this issue. The defendants plead that the first defendant has been in the business of manufacturing and selling IDEALmold machines "since on or around 1999/2000". At trial, Yuen Chun On ("Yuen"), the first defendant's senior sales manager accepted that the first defendant has manufactured (*ie*, made), sold (*ie*, disposed of), offered for sale (*ie*, offered to dispose of) and kept the IDEALmold machine. It can also be safely inferred that these infringing acts were done in Singapore (as s 66(1) of the Patents Act requires) as the first defendant is a Singaporean company and this point is, in any event, not disputed by the defendants. Accordingly, I find that the first defendant has infringed Claims 4 and 5 by making, disposing of, offering to dispose of and keeping the IDEALmold machine.

(2) Claims 1 and 2 (process claims)

99 As Claims 1 and 2 are process claims, the relevant provision is s 66(1)(b) of the Patents Act. The infringing act alleged against the first defendant in relation to Claims 1 and 2 is that of offering for use.

100 A difficulty arises because the plaintiff does not actually allege that the first defendant had offered the allegedly infringing process (*ie*, the operation of the IDEALmold machine) for use. Rather, the plaintiff relies on the first defendant's selling and offering for sale of the IDEALmold machine and submits that, as a matter of law, selling and offering for sale a *product* which incorporates an infringing process is equivalent to offering the infringing *process* for use. The basis for this submission is the decision of the English Patents Court in *Tamglass Ltd OY v Luoyang North Glass Technology Co Ltd and another* [2006] EWHC 65 (Ch) ("*Tamglass*"). The court in *Tamglass* found (at [15]–[16]) that the machine in question had infringed the patent in that case. As the first defendant in *Tamglass* had imported the machine and supplied it to the second defendant, the first defendant had infringed in

relation to the product claim in the patent by importing for the purposes of s 60(1)(a) of the UK Patents Act 1977 (c 37) (UK) ("the UK Patents Act") (which is similar to s 66(1)(a) of the Patents Act) (at [35]). The court then went to state (at [36]), in a passage relied on by the plaintiff, as follows:

So far as the inventions are processes it is said that [the first defendant] offered those processes for use in the UK knowing that they infringed, or in circumstances in which it was obvious to a reasonable person that their use without consent would be an infringement. I find that these requirements are fulfilled.

The court then cited (at [37]) two instances where the first defendant had made what the court considered to be offers for what appears to be the sale of the machine.

101 The defendants submit that this approach dilutes and renders meaningless the division between the different infringing acts of product patents and process patents in s 66 of the Patents Act. Moreover, there was no argument and reasoning set out for this approach in *Tamglass*.

102 Given my earlier finding that Claims 4 and 5 have been infringed by the first defendant, it is, strictly speaking, not necessary for me to make a determination on this point. It is apparent that the exact same machines are involved in both sets of claims and a finding that the first defendant has also infringed Claims 1 and 2 is unlikely to have any practical implication.

103 That said, I am in general agreement with the plaintiff's submission, although I do think that it could have been phrased more clearly. As I see it, the plaintiff's submission is really that offering an infringing process for use *includes* the selling and offering for sale of a product which incorporates the infringing process. Subject to the proviso that that product must be intended to be used by the offeree, there are two reasons why I agree with this submission.

104 First, this submission is a self-evident one: a defendant who sells or offers for sale a product which incorporates an infringing process must, if that product is intended to be used by the offeree, be taken to have offered the incorporated infringing process for use. In this regard, I fail to see how there is, as the defendants claim, a dilution or rendering meaningless of the different infringing acts of product patents and process patents. The focus here is still on the "offer for use" limb of s 66(1)(b) of the Patents Act and, in my view, the wording of this limb is broad enough to include the scenario set out in the plaintiff's submission (subject to the proviso).

105 Second, the defendants have not cited any authority to the contrary. I accept that the decision in *Tamglass* is bereft of argument and reasoning in so far as this point is concerned. However, if, as I have held at [104] above, the plaintiff's submission is a self-evident one, then there really would have been no need for anything further to have been said about it. In this connection, I note that *Tamglass* has been discussed without criticism in two paragraphs of a leading patents textbook (Colin Birss *et al*, *Terrell on the Law of Patents* (Sweet & Maxwell, 18th Ed, 2016) at paras 14-92-14-93).

106 As such, I find that offering an infringing process for use includes the selling and offering for sale of a product which incorporates the infringing process, provided that that product is intended to be used by the offeree. It follows from [98] above that the first defendant has offered Claims 1 and 2 for use in Singapore.

107 This, however, is not the end of the matter as there are two further requirements under s 66(1)(b) of the Patents Act that must be satisfied in order for liability to attach. First, the offer

must not only be made in Singapore but must also relate to the use of the infringing process in Singapore (*Institut Pasteur and Another v Genelabs Diagnostics Pte Ltd and Another* [2000] SGHC 53 at [225]; *Law of Intellectual Property of Singapore* at para 33.2.2). There is unfortunately little evidence on this point. For the purposes of ascertaining liability, however, I am prepared to infer that this was the case. Although Yuen in his AEIC stated that the first defendant offers the IDEALmold machine for sale to its customers which are "from all over the world", he also said at trial that he had given presentations on the IDEALmold machine both locally and overseas. As such, at least some of the first defendant's customers were probably based in Singapore and the offer for use would have related to the use of the IDEALmold machine in Singapore.

108 The second further requirement is that the first defendant must have known, or it would have been obvious to a reasonable person in the circumstances, that the use of the IDEALmold machine would have been infringing. I find this requirement to be satisfied on the evidence. The application for the Patent was published on 15 June 1998; the IDEALmold machine was sold by the first defendant from "at least 1999/2000". Wee gave evidence that in 1998, the research and development team dedicated to automoulding machines was staffed with 30 to 50 persons. He agreed that, as a team, they would be looking out at the industry for the latest innovations and trends. Moreover, there was also evidence that there are not many companies in the moulding machine industry because the manufacture of moulding machines is an endeavour that has high barriers to entry and requires highly-specialised technical skills and technology. Against this image of a highly-competitive industry with few players, I find that even if the first defendant did not know of the Patent and, consequently, that the use of the IDEALmold machine would have been infringing, these would have been obvious to a reasonable person in the circumstances.

109 Accordingly, I find that the first defendant has infringed Claims 1 and 2 by offering for use the operation of the IDEALmold machine.

Second defendant

110 The plaintiff's claim against the second defendant relates only to Claims 4 and 5. The infringing acts identified in the pleadings pertain to the second defendant's alleged making and keeping of the IDEALmold machine. However, the plaintiff's closing submissions refer only to the former.

111 The plaintiff's case against the second defendant rests solely on the fact that the nameplates of some IDEALmold machines stipulate "ASM Pacific Technology" as the manufacturer. Photographs of these nameplates were adduced in evidence. In contrast to the nameplates in these photographs, the nameplates in the other photographs in evidence indicate "ASM Technology Singapore" as the manufacturer. The plaintiff says that "ASM Pacific Technology" is the corporate name of the second defendant.

112 On the other hand, the defendants explain that the use of "ASM Pacific Technology" on the nameplates was the result of a restructuring exercise. In 2010, there were plans to restructure the group of companies owned by the second defendant ("the ASMPT Group") into a "Principal Company Structure". In connection with the restructuring, the chief executive officer of the second defendant, Lee Wai Kwong ("Lee"), decided that the ASMPT Group should adopt a common identity or brand for the companies in the ASMPT Group. In an email dated 12 May 2010, Lee decided that the brand name "ASM Pacific Technology" would be used to identify the products emanating from entities in the ASMPT Group. However, the first defendant continued to manufacture and sell the IDEALmold machine as it had always done, although the nameplates were changed to refer to "ASM Pacific Technology" pursuant to the objective of realising a common brand identity.

113 In my judgment, the nameplates alone are an insufficient basis for me to conclude that the second defendant has infringed Claims 4 and 5 by making and/or keeping the IDEALmold machine. The evidence, as a whole, supports the defendants' explanation.

114 First, there is documentary evidence which directly supports the defendants' explanation. In particular, the email from Lee dated 12 May 2010 unequivocally expresses the desire for a common identity or brand and in fact directs that implementation should follow. The email reads as follows:

Dear all,

It is time for us to promote a unique company identity to outside – ASM Pacific Technology.

For all our products, software, product brochures, catalogs, .. etc, we should always use ASM Pacific Technology instead of ASM Assembly Automation or ASM Technology Singapore. For all big multi-national companies you always see a unique company identity. We as a customer will not be able to know where was a particular product designed and manufactured. We buy an iPhone from Apple, not Apple HK or Apple Singapore. Similarly we buy a notebook computer from Dell, Lenovo or HP and when you boot up the computer they will not show you Dell Malaysia, Lenovo Shanghai or HP USA.

Please organize the efforts in your area to achieve the above objective.

Best regards,

WK Lee

The plaintiff casts doubt on the veracity of the defendants' explanation but does not put forth an alternative interpretation of this email. Neither does it suggest that this email is a fabrication. This being the case, a strong piece of evidence is left unchallenged.

115 Apart from this email, another piece of documentary evidence which supports the defendants' explanation is Yuen's name card. Yuen is an employee of the first defendant and his name card unsurprisingly bears the name of the first defendant in full, *ie*, "ASM Technology Singapore Pte Ltd". However, Yuen's name card *also* has a stylised logo bearing the words "ASM Pacific Technology". This strongly suggests that "ASM Pacific Technology" is really nothing more than a brand name.

116 I accept, however, that there is some documentary evidence which is inconsistent with the defendants' explanation. For instance, the first defendant's letter template continued to comprise a stylised logo bearing the words "ASM Technology Singapore" even as late as November 2012. (Oddly, this template also has a reference to "ASM Pacific Technology *Group*".) Marketing materials used by the first defendant in October 2011 also bore the words "ASM Pacific Technology Ltd" in the copyright notice. Yuen's evidence is that the inclusion of "Ltd" was made in error, but I find this to be a rather convenient excuse. However, these inconsistencies could well have been a result of imperfect implementation. More importantly, they do not account for the documentary evidence which *does* suggest that there was in fact a branding exercise.

117 Second, the nameplates themselves are consistent with the defendants' explanation. The nameplates also state the manufacturing date of the machine in question. Among the photographs of the nameplates which are in evidence, the four which bear a later manufacturing date state "ASM Pacific Technology" as manufacturer, while the four which bear an earlier manufacturing date state the manufacturer as "ASM Technology Singapore". Admittedly, there is some lag time: Lee's email was

sent on 12 May 2010 but "ASM Technology Singapore" is still stated as manufacturer on a nameplate bearing a manufacturing date of July 2010. However, I do not consider this to be fatal as it is only expected that some lag time would be involved in the implementation of what appears to me to be a fairly large-scale branding exercise. Furthermore, although "ASM Pacific Technology" is stated as the manufacturer on some of the nameplates, the address on these nameplates remains that of the first defendant. This point is not that strong as there was some indication at trial that the second defendant (which has its registered address in Hong Kong) had some presence at the first defendant's address. Nonetheless, it is still of some probative value when considered alongside the rest of the evidence.

118 Third, the defendants' pleaded case is that the second defendant is an investment holding company that was, at all material times, not involved in manufacturing. Yuen said in his AEIC that the second defendant was and is not a manufacturer and he confirmed at trial that the second defendant was never ever a manufacturer of the IDEALmold machine. All this is objectively and squarely supported by the second defendant's 2010 Annual Report, which states as follows:

PRINCIPAL ACTIVITIES

The Company acts as an investment holding company. Its principal subsidiaries are engaged in the design, manufacture and marketing of machines, tools and materials used in the semiconductor industry.

I note that the Hong Kong Stock Exchange's website states the second defendant's principal activities as including the manufacture of machines. However, I give greater weight to the description of the second defendant's principal activities as stated in its 2010 Annual Report as this emanated from the second defendant itself and is therefore likely to be a more accurate representation of the second defendant's activities.

119 Finally, it is also doubtful if "ASM Pacific Technology" is even a reference to the second defendant in the first place. The second defendant's full name is "ASM Pacific Technology Limited". I do accept, however, that the earlier nameplates of the IDEALmold machine simply state "ASM Technology Singapore" as manufacturer (see [111] above), and this is also not the first defendant's full name.

120 All things considered, the defendants' explanation is, in my view, believable. Although there are some inconsistencies in the evidence, I find that, on balance, these inconsistencies do not detract from the overall veracity of the defendants' explanation. Accordingly, I am of the view that the reference to "ASM Pacific Technology" on the nameplates of some IDEALmold machines is not a reference to the second defendant and that the second defendant was not the manufacturer of these machines. Accordingly, the second defendant has not infringed Claims 4 and 5.

Joint tortfeasorship by common design

(1) The law

121 The law on joint tortfeasorship can be divided into two broad categories: (a) where one party conspires with the primary party or induces the commission of the tort; and (b) where two or more persons join in a common design pursuant to which the tort is committed (*Trek* at [35]). The plaintiff's claim for joint infringement concerns the latter category.

122 In this regard, the High Court in *Trek* approved (at [37]) the following passage from *Morton-*

Norwich Products Inc and Others v Intercen Limited [1978] RPC 501 (at 512):

... As I understand it, persons whose respective shares in the commission of a tortious act are done in furtherance of a common design are properly regarded as joint tortfeasors: see Clerk and Lindsell on Torts, 14th ed., page 201, and the references *inter alia* to *The Kursk* [1924] page 140 per Scrutton, L.J. at page 155. It is clear from this that *two persons who agree on common action in the course of and to further which one of them commits a tort in this country are joint tortfeasors*. There is, as Scrutton, L.J. said, one tort committed by one of them on behalf of and in concert with the other. ... [emphasis added]

Referring to *Unilever Plc v Gillette (UK) Limited* [1989] RPC 583, the High Court further noted (at [38]) that for parties to operate in furtherance of a common design, it is not necessary for them to have mapped out a plan; tacit agreement will also suffice.

123 In *Bradley Lomas Electrolok Ltd and another v Colt Ventilation East Asia Pte Ltd and others* [1999] 3 SLR(R) 1156 ("*Bradley Lomas*"), the respondents, Colt Ventilation East Asia Pte Ltd ("Colt VEA"), Colt International Limited ("Colt Intl") and Colt Group Limited ("CG Ltd") were companies within the Colt group of companies. The appellants originally sued Colt VEA for patent infringement, the alleged infringement relating to a product which was being sold in Singapore by Colt VEA. However, the appellants later obtained an order to add Colt Intl and CG Ltd as defendants. Colt Intl and CG Ltd then applied to set aside the order. By the time the matter reached the Court of Appeal, the only issue was whether CG Ltd should be made a defendant. The Court of Appeal held (at [23]) that it was clearly not enough to merely point to the fact that Colt VEA and CG Ltd were closely related to one another either by shareholding or otherwise; some other evidence of CG Ltd's *actual involvement* in furthering the common design of infringement had to be shown. The Court of Appeal then held (at [26]) as follows:

So taking the factors identified by the appellants in their totality, namely, *the fact that CG Ltd owned almost 100% of Colt VEA, there was common management, the companies used the same logo and that the accounts of Colt VEA would be consolidated with CG Ltd, they are **not indicative of participation or involvement of CG Ltd in the tort***. Evidence of involvement of each company within a group is necessary (without considering the question of veracity of that evidence) before that company may be joined in the proceedings as a joint tortfeasor. Otherwise, it would mean that a holding company would always be dragged into proceedings involving its subsidiaries. [emphasis added in italics and bold italics]

124 I accept that the Court of Appeal in *Bradley Lomas* was not concerned with the merits of a joint tortfeasorship claim *per se*. However, there is no reason why this should make a difference. As such, the threshold for a finding of joint tortfeasorship by common design is a high one. Indeed, it has been observed that such a finding "requires the discharge of a heavy evidentiary burden on the part of the plaintiff" (Susanna H S Leong, *Intellectual Property Law of Singapore* (Academy Publishing, 2013) at para 19.045).

(2) Analysis

125 The plaintiff's claim for joint infringement rests on various alleged agreements and arrangements between the defendants. Although this claim is pleaded as being against both defendants, it is clear from the pleaded infringing acts (which are the same as those alleged against the first defendant), as well as the thrust of the plaintiff's submissions, that this claim is really directed at the liability of the second defendant for its purported involvement in the first defendant's infringing acts, which have already been discussed at [98]–[109] above. I find, however, that the plaintiff's claim for joint

infringement is not established.

126 First, a number of the plaintiff's submissions can be dismissed outright even without a consideration of their truth or their substantive merits. Bearing in mind the caution in *Bradley Lomas* (see [123] above), it is insufficient for the plaintiff to point to: (a) Yuen's apparent agreement that the defendants were "practically ... the same company"; (b) the apparent fact that the first defendant's executive staff were on the second defendant's payroll; (c) the apparent fact that some of the top management personnel of the second defendant were stationed in Singapore at the first defendant's premises; (d) the apparent fact that the name cards of the employees of the first and second defendants bore the same reference to "ASM Pacific Technology" and made no distinction between the defendants; or (e) the apparent fact that the second defendant's representatives were present at trade shows where the first defendant marketed the IDEALmold machine. All these fall far short of establishing the second defendant's actual involvement in furthering the common design of infringement.

127 Second, other submissions by the plaintiff are purely speculative. For example, the plaintiff refers to Yuen's evidence that the final IDEALmold machine comprises of parts that are purchased and parts that are fabricated. The purchased parts are bought by the first defendant from a subsidiary of the second defendant which specialises in central purchasing, while the fabricated parts are fabricated by subsidiaries of the second defendant. The plaintiff submits that instructions to these subsidiaries "can only come" from the second defendant. However, this submission is simply not borne out by the evidence. In fact, Yuen testified, quite to the contrary, and at least in relation to central purchasing, that where the IDEALmold machine was concerned, the subsidiary actually took instructions from the first defendant.

128 A similar submission by the plaintiff relates to the sale of the IDEALmold machine. There was evidence that although such sale was generally made by the first defendant, there were occasions when it was made in the name of other subsidiaries of the second defendant. Yuen said that he was not aware of how the sales receipts were accounted for internally within the ASMPT Group. From this, the plaintiff submits that such accounting "can only be directed and controlled" by the second defendant. Quite plainly, this submission is based more on speculation than evidence.

129 Third, the remaining submissions by the plaintiff also do not withstand scrutiny. For instance, the plaintiff refers to marketing materials used by the first defendant and points to the reference to "ASM Pacific Technology Ltd" in the copyright notice. However, Yuen's evidence is that all these materials were created and used by the first defendant. These marketing materials therefore do not implicate the second defendant at all. A further point made by the plaintiff *vis-à-vis* these marketing materials relates to Yuen's evidence at trial that the template for these materials belonged to the second defendant and the first defendant had no choice but to use it. However, these marketing materials do not all relate to the IDEALmold machine. In fact, although not entirely clear, Yuen's evidence on this point appears to relate to a set of materials for another machine. Consequently, I do not think that what appears to be a *general* direction by the second defendant to the first defendant concerning the use of templates for the latter's marketing materials suffices to establish the second defendant's actual involvement in furthering the common design of infringement.

130 The plaintiff also points to the second defendant's website, which features and offers the IDEALmold machine for sale and which lists the first defendant as the contact point in Singapore. The plaintiff further refers to how Yuen had agreed that the second defendant has "absolute control" over the contents of its website. However, there is no evidence as to what this "absolute control" entailed. The second defendant has over a hundred subsidiaries around the world. In light of this, I do not think that when Yuen agreed that the second defendant has "absolute control" over the contents

of its website, he meant to say that the second defendant provided or even approved the detailed content that went onto its website. This is all the more so given Yuen’s evidence that the website was managed by employees of the first defendant and that the information on the IDEALmold machine on the website was received by the team responsible for the website from the automoulding department before being included on the website. In these premises, any “control” exercised by the second defendant would have, at most, been in the form of general oversight and I do not think that this sufficiently establishes the second defendant’s actual involvement in furthering the common design of infringement.

131 Lastly, the plaintiff also draws my attention to Lee’s email of 12 May 2010 (see [114] above). However, the plaintiff’s submission that Lee had given directions to the first defendant on the branding of the IDEALmold machine in this email is completely without merit because the email makes no specific mention of the IDEALmold machine at all. Similar to the reasoning at [129] above, Lee’s general direction concerning the branding exercise does not suffice to establish the second defendant’s actual involvement in furthering the common design of infringement.

132 Accordingly, I find that the plaintiff’s claim for joint tortfeasorship by common design is not established.

Summary on prima facie liability for infringement

133 At this juncture, it is appropriate to summarise my findings on *prima facie* liability for infringement. These are set out in the following table:

Pleaded infringing acts		
First defendant	Claims 1 and 2 (process claims)	Infringement
	Claims 4 and 5 (product claims)	Infringement
Second defendant	Claims 4 and 5 (product claims)	No infringement
Both defendants (j o i n t tortfeasorship by common design)	Claims 1 and 2 (process claims)	No infringement
	Claims 4 and 5 (product claims)	No infringement

Accordingly, the first defendant is *prima facie* liable for infringing Claims 1, 2, 4 and 5. There is no liability for infringement on the part of the second defendant.

134 Given these findings, a further point arises. This relates to a rather peculiar submission made by the defendants. This submission is as follows:

The implication by the Plaintiff’s pleading is that if the court agrees that the 2nd Defendant is not liable for direct infringement from 2010 onwards, the Plaintiff never plead [*sic*] that the 1st

Defendant is liable. Accordingly, by the pleadings, neither of the Defendants can be liable for any act from 2010 onwards.

Although no reference is made to any particular part of the plaintiff's pleadings, it appears that the defendants have in mind the following part of the plaintiff's Particulars of Infringement (Amendment No 1):

In particular, the Plaintiff relies on the following primary acts of infringement by the Defendants:

(a) In or around 2006, 2008, 2009 and 2010, [the first defendant] manufactured and kept the IDEALmold machine in Singapore.

(b) In or around 2010, 2011 and 2012, [the second defendant] manufactured and kept the IDEALmold machine in Singapore. On these machines, [the second defendant] is stipulated as the manufacturer, which is located at the registered address of [the first defendant].

(c) In or around 2010, [the first defendant] disposed of an IDEALmold machine to International Rectifier Mexico.

...

135 The plaintiff, on the other hand, refers to O 87A r 2(2) of the ROC (see [80] above), which requires the plaintiff to give an instance of the defendants' infringing acts. The plaintiff submits that giving an instance in a particular year does not mean that the plaintiff is only claiming for that instance of infringement.

136 I agree with the plaintiff's submission. O 87A r 2(2) of the ROC requires a plaintiff to serve particulars of infringement: (a) showing which of the claims in the specification of the patent are alleged to be infringed; and (b) giving at least one instance of each type of infringement alleged. In the present case, it is not, and it cannot be, disputed that (a) has been done. As for (b), the part of the plaintiff's Particulars of Infringement (Amendment No 1) referred to at [134] above merely sets out instances of the alleged infringement which are not intended to be, and which are not required to be, exhaustive. I therefore reject the defendants' submission accordingly.

Are there any defences available to the first defendant?

137 As I have found that the first defendant is *prima facie* liable for infringing the Patent, the next broad issue is whether there are any defences available to the first defendant. In the present case, the defendants rely on two categories of defences: (a) "delay" defences; and (b) "remedy" defences.

"Delay" defences

138 With respect to the "delay" defences, the defendants rely on s 6 of the Limitation Act as well as the defences of estoppel, delay, laches and acquiescence. At trial, counsel for the plaintiff accepted that the Limitation Act applied and that the plaintiff is "only entitled to go back six years". The same concession is also made in the plaintiff's closing submissions. It is therefore not necessary for me to make any finding on this issue. As for the remaining defences, despite the many words used by the defendants, it is clear from their reliance on *Dynasty Line Ltd (in liquidation) v Sia Sukamto and another* [2013] 4 SLR 253 that only two defences are being relied upon, *viz*, acquiescence and laches.

The law

139 The equitable principle of laches was examined in considerable detail by the High Court in *Tan Yong San v Neo Kok Eng and others* [2011] SGHC 30 ("*Tan Yong San*"). The High Court observed (at [98]) that the general principle is that laches would operate to bar the grant of *equitable relief*, whether or not the underlying claim originated in common law or equity. In *Tan Yong San*, the plaintiff's claim was founded on s 216 of the Companies Act (Cap 50, 2006 Rev Ed) ("Companies Act"), which also makes available a range of remedies to an aggrieved complainant. As the remedies sought by the plaintiff were derived from statute and not from equity, the *prima facie* position was that laches did not bar his right to claim for relief under s 216 of the Companies Act (at [101]). However, the High Court opined (at [101]) that this view would be too simplistic: although a claim under s 216 of the Companies Act was statutory in nature, the principles on what constituted oppressive or unfairly prejudicial conduct were heavily influenced by considerations of fairness and equity. Thus, the High Court held (at [105]) that the court in an action under s 216 of the Companies Act could take into account equitable defences such as laches in determining whether there had been oppressive conduct and in awarding any consequential relief.

140 The High Court then noted (at [109]) the Court of Appeal's holding in *Management Corporation Strata Title Plan No 473 v De Beers Jewellery Pte Ltd* [2002] 1 SLR(R) 418 that there were two elements to consider when raising the defence of laches: (a) the length of the delay; and (b) whether such delay had caused any prejudice or injustice. With respect to the first limb, the High Court referred (at [109]) to the proposition in *Beale v Kyte* [1907] 1 Ch 564 (at 566) that:

... in order that laches or acquiescence may be a defence there must be *notice of the error*, and *time runs from the date of the notice and not from the time when the error is committed*; and it is inconceivable to my mind that on a question of laches time can run from the time the mistake was committed. It seems to me it must run from the time when the plaintiff's attention is first called to the error. [emphasis added]

The High Court further noted (at [110]) that in *Genelabs Diagnostics Pte Ltd v Institut Pasteur and another* [2000] 3 SLR(R) 530, the Court of Appeal had, in computing the length of delay, only took into account the period starting from when the plaintiffs first became aware of the infringing acts.

141 The defence of acquiescence was also examined by the High Court in *Tan Yong San*. In this respect, the High Court referred (at [112]) to the following passage from *Halsbury's Laws of England* vol 16 (Butterworths, 4th Ed Reissue, 1992) (at para 924) (the same passage is now found in *Halsbury's Laws of England* vol 47 (LexisNexis, 5th Ed, 2014) at para 252):

The term 'acquiescence' is ... properly used where a person having a right, and seeing another person about to commit, or in the course of committing, an act infringing that right, stands by in such a manner as really to induce the person committing the act, and who might otherwise have abstained from it, to believe that he assents to its being committed; a person so standing by cannot afterwards be heard to complain of the act. In that sense the doctrine of acquiescence may be defined as quiescence under such circumstances that assent may be reasonably inferred from it, and is no more than an instance of the law of estoppel by words or conduct ...

142 The High Court then went on to caution (at [113]) that although acquiescence is frequently pleaded together with the defence of laches, the two are separate and distinct defences with different consequences. The High Court explained (at [114]) that:

Thus, laches in its strict sense refers only to delay on the part of the plaintiff coupled with prejudice to the defendant. As explained above ... laches can only be used as a defence against a

claim for equitable relief. Acquiescence on the other hand is premised not on delay, but on the fact that the plaintiff has, by standing by and doing nothing, made certain representations to the defendant in circumstances to found an estoppel, waiver, or abandonment of rights... Unlike laches, the defence of acquiescence is not limited to resisting claims for equitable relief.

Analysis

(1) Laches

143 With regard to the defence of laches, the threshold issue is whether the remedies sought by the plaintiff are equitable in nature, so as to allow for the operation of this defence. The plaintiff submits that the reliefs it seeks are statutory reliefs provided for by s 67(1) of the Patents Act and that it is therefore unclear what legal basis the defendants have for relying on this defence. This is a valid contention. Although the High Court in *Tan Yong San* was willing to extend the operation of the laches defence to a claim under s 216 of the Companies Act (see [139] above), I do not think that the reasoning in that case is capable of applying *vis-à-vis* a claim for patent infringement, which is of a rather different character altogether. In any event, I am of the view that the two elements referred to in *Tan Yong San* (see [140] above) are not established on the facts of the present case.

144 With respect to the first element (*ie*, the length of the delay), Hiroyuki Kanamaru, a senior manager of the plaintiff's product planning department, gave evidence as follows:

(a) Around 2001, the plaintiff became aware of the defendants. However, the plaintiff did not pay much attention to the defendants because the plaintiff saw the defendants as a relatively unknown company with a very small market share.

(b) Around 2003/2004, the plaintiff started receiving feedback from its customers that the defendants were marketing moulding machines to them. However, the plaintiff did not have any substantive details of these machines. There was also no reason for the plaintiff to incur the time and costs of seeking such details because the plaintiff still saw the defendants as a relatively unknown company with a very small market share.

(c) Around 2005/2006, the plaintiff started receiving feedback from its customers that the defendants were selling the IDEALmold machine and at a lower price as compared to the plaintiff. However, the plaintiff still did not have any substantive details of the IDEALmold machine. There was also still no reason for the plaintiff to incur the time and costs of seeking such details because the plaintiff still saw the defendants as a relatively unknown company with a very small market share.

(d) Around 2009, the plaintiff's engineers saw the IDEALmold machine at the premises of a customer. However, there was still no reason for the plaintiff to incur the time and costs of seeking detailed information of the IDEALmold machine.

(e) In 2010, the defendants and the IDEALmold machine emerged as a serious competitor to the plaintiff. This prompted the plaintiff to conduct research and investigations to better understand the IDEALmold machine.

(f) It was only sometime in July 2011, after evaluating the results of the investigations, that the plaintiff came to the view that the IDEALmold machine infringed the Patent. On 25 July 2011, the plaintiff wrote to the second defendant to register its objections.

145 Thereafter, letters were exchanged between the parties up till 6 November 2012. On 4 March 2013, a letter of demand was sent by counsel for the plaintiff to the first and second defendants. A series of letters between counsel for the plaintiff and counsel for the defendants (who, it seems, was only acting for the first defendant then) then followed, the latest of which (which is in evidence) was sent on 26 April 2013. The writ of summons was filed on 19 April 2013 but only served on the first defendant on 2 May 2013 and on the second defendant on 22 May 2013.

146 The plaintiff accepts that it was aware of the IDEALmold machine from as early as 2005. However, it submits, and I agree, that this is irrelevant as time only starts running from the point at which the plaintiff was aware that the IDEALmold machine *infringes* the Patent (see [140] above). But this was only in July 2011 (see [144(f)] above). Thereafter, the plaintiff took steps to engage the defendants and parties were in correspondence with each other until the writ was served. In these premises, I do not see how it can be said that there was any delay on the part of the plaintiff from the time it was aware that the IDEALmold machine infringes the Patent.

147 Moreover, even if there was any such delay, the defendants have not adduced any evidence to show that the first defendant has suffered prejudice or injustice as a result of the delay. Accordingly, the second element (*ie*, whether such delay has caused any prejudice or injustice) would not, in any event, be satisfied.

(2) Acquiescence

148 As to the defence of acquiescence, the defendants submit as follows:

... The Plaintiff stood by while the 1st Defendant was a "very small" competitor and allowed the 1st Defendant to become a "serious competitor". Since 2001, the Plaintiff allowed the 1st Defendant to grow unhindered. This is not an example of neglect (which would be sufficient to found the delay defences), but of deliberate and wilful conduct and allowance. Any reasonable competitor would on the facts be induced and lead [*sic*] to believe that there was consent in the nature of estoppel, waiver or abandonment of rights.

149 In my opinion, the defendants' suggestion is rather fanciful. What the defendant is saying is that the plaintiff had "allowed" the first defendant to "grow unhindered", only to now suddenly take action against it in the Suit. Perhaps more importantly, acquiescence is where a person, having a right, and seeing another person about to commit, or in the course of committing, an act infringing that right, stands by in such a manner as really to induce the person committing the act, and who might otherwise have abstained from it, to believe that he assents to its being committed (see [141] above). As I have already stated, the plaintiff only became aware that the IDEALmold machine infringes the Patent in July 2011 and thereafter took steps to engage the defendants (see [146] above). Certainly, there could not have been any acquiescence on the part of the plaintiff post-July 2011. As for the period up to July 2011, I do not see how the plaintiff, without even being aware that the IDEALmold machine infringes the Patent, can be said to have stood by "in such a manner as really to induce" the first defendant to believe that it assented to the infringing acts being committed.

150 Accordingly, I find that the first defendant cannot avail itself of the "delay" defences of laches and acquiescence.

"Remedy" defences

151 In addition to the "delay" defences, the defendants also rely on a number of "remedy" defences.

152 First, the defendants rely on s 69(1) of the Patents Act, which provides that damages shall not be awarded and no order shall be made for an account of profits against a defendant who proves that at the date of the infringement he was not aware, and had no reasonable grounds for supposing, that the patent existed. For the same reasons set out at [108] above, this defence is not open to the first defendant.

153 Second, the defendants rely on s 70 of the Patents Act, which provides for relief for the infringement of partially valid patents. Given my conclusion at [75] above that the Patent is fully valid, it is obvious that this section does not apply in the present case.

154 Third, the defendants submit that in view of the delay and "other bad behaviour" demonstrated by the plaintiff, the plaintiff should be deprived of the option to seek an account of profits. I have already considered and rejected the defendants' submissions on the issue of delay (see [146] above). As for the plaintiff's supposed "other bad behaviour", it appears that this would refer to the defendants' various allegations including, *inter alia*, that the plaintiff was aware of the prior art and that the plaintiff had undermined discovery, the court's fact-finding function and the duty of its expert to the court. However, even apart from the somewhat baseless and irrelevant nature of these allegations, I do not consider these allegations, even if true, to be sufficient to deprive the plaintiff of the option of an account of profits on the facts of the present case.

155 Finally, although not raised as a defence *per se*, the defendants submit that the measure of damages must always be what is directly attributable to the Patent, and there must be proper apportionment between the Patent and other technologies. The point here seems to be that there are other patents in the plaintiff's Y-series machine (which apparently embodies the Patent) and these also contribute to the sales of the Y-series machine. This submission is somewhat surprising given the defendants' earlier claim, in its closing submissions, that the Y-series machine is "strictly not relevant at all in these proceedings". In any event, the defendants do not cite any authority for this proposition and do not suggest how apportionment should be done.

156 Accordingly, I find that none of the "remedy" defences relied on by the defendants are available to the first defendant.

Is the plaintiff liable for making groundless threats of infringement proceedings?

157 As I have found that the second defendant is not liable for infringement, the final broad issue to be considered is whether the plaintiff is liable for making groundless threats *vis-à-vis* the second defendant. In this regard, s 77 of the Patents Act states as follows:

Remedy for groundless threats of infringement proceedings

77.—(1) Where a person (whether or not the proprietor of, or entitled to any right in, a patent) by circulars, advertisements or otherwise threatens another person with proceedings for any infringement of a patent, a person aggrieved by the threats (whether or not he is the person to whom the threats are made) may, subject to subsection (4), bring proceedings in the court against the person making the threats, claiming any relief mentioned in subsection (3).

(2) In any such proceedings, the plaintiff shall, if he proves that the threats were so made and satisfies the court that he is a person aggrieved by them, be entitled to the relief claimed unless

(a) the defendant proves that the acts in respect of which proceedings were threatened constitute or, if done, would constitute an infringement of a patent; and

(b) the patent alleged to be infringed is not shown by the plaintiff to be invalid in a relevant respect.

(3) The said relief is —

(a) a declaration to the effect that the threats are unjustifiable;

(b) an injunction against the continuance of the threats; and

(c) damages in respect of any loss which the plaintiff has sustained by the threats.

(4) Proceedings may not be brought under this section for a threat to bring proceedings for an infringement alleged to consist of making or importing a product for disposal or of using a process.

(5) It is hereby declared that a mere notification of the existence of a patent does not constitute a threat of proceedings within the meaning of this section.

(6) Nothing in this section shall render an advocate and solicitor or any other person liable to an action under this section in respect of an act done by the advocate and solicitor or the other person in his professional capacity on behalf of a client.

158 Wee's evidence, as set out in his AEIC, is as follows:

The 1st Defendant has suffered damages from lost orders and have been put to expense and cost due to the Plaintiff's threats of instituting infringement proceedings against the Defendants. The Defendants have had to devote much time to answering the threats, distracting the Defendants from its business. ...

159 The plaintiff does not appear to dispute that threats of infringement proceedings were indeed made. Rather, its main contention is that the defendants have not proved that they were aggrieved by the threats. In this regard, the plaintiff submits that Wee's evidence is not substantiated by any other documents or evidence. I also note that, in the first sentence of Wee's evidence as set out above, Wee is referring only to the first defendant. What is left is therefore Wee's evidence that the second defendant had to "devote much time to answering the threats, distracting [it] from its business". The issue is whether this is sufficient to establish that the second defendant is a "person aggrieved" under s 77 of the Patents Act.

160 In *Patrick John Brain v Ingledew Brown Bennison and Garrett (a firm) and another (No. 3)* [1997] FSR 511, Laddie J said the following concerning the legislative intent behind the inclusion of "person aggrieved" in s 70(1) of the UK Patents Act (which is similar to s 77(1) of the Patents Act) (at 519):

... It seems to me that the legislative intent behind the inclusion of "person aggrieved" in section 70(1) is to exclude frivolous applications or applications by busybodies who have no real personal interest in the threats. As [counsel for the plaintiff] put it, someone who has no interest in the matter and is suffering nothing from it should not be regarded as a person aggrieved. Mere hurt feelings are not enough, but if, for example, a trader's chosen route to exploitation of his product or process is interfered with by the threat, that is damage in the broad sense and makes him a

person aggrieved. It is not necessary to prove that the interference has achieved the threatener's objective. The fact that the trader is able to assuage the fears of his potential customers or partners so that the threat has in fact produced no recoverable loss, does not mean he is not aggrieved by it and the prospect of similar threats in the future. *He has a real, as opposed to fanciful, commercial interest which has been interfered with and, as a result, he has a grievance which the court will recognise.* [emphasis added]

Subsequently, he further held (at 520) that:

... For the purpose of demonstrating that he has status to sue, what [the plaintiff] has to do is show that his commercial interests are or are likely to be adversely affected in a real as opposed to a fanciful or minimal way. Where the threats are made against him directly ... the court will infer such adverse effect. Where the threats are made indirectly, he will need to demonstrate it. But I do not think the court should be astute to find that a complainant has not been affected in his commercial activities where it is clear that the purpose of the threats was to do so. ...

161 The upshot of these passages is that s 77 of the Patents Act is concerned with the *commercial interests* of a plaintiff who brings a claim under the section. Specifically, the section only covers those who are affected by such threats due to the nature of their business. However, by the defendants' own case (see [11(f)] above) (which I have accepted (see [118] above)), the second defendant is an investment holding company and was not involved in manufacturing or sales operations at all material times. In these premises, I cannot see how the plaintiff's threats involving the IDEALmold machine could have affected the conduct of the second defendant's business (*ie*, its commercial interests) in any way.

162 I appreciate that Wee's evidence is limited to the second defendant having to "devote much time to answering the threats, distracting [it] from its business". However, this does not seem to implicate the more specific kind of commercial interests protected by s 77 of the Patents Act. In any event, I am in agreement with the plaintiff that this claim is not substantiated by any other evidence.

163 Consequently, I find that the second defendant is not a "person aggrieved" under s 77 of the Patents Act. It follows that the plaintiff is not liable to the second defendant for making groundless threats of infringement proceedings.

164 I should add that even if I had found for the second defendant on this issue, I would not have been inclined to grant it damages pursuant to s 77(3)(c) of the Patents Act for the same reason set out at [161] above. The only loss sustained by the second defendant as a result of the plaintiff's threats is the cost of the Suit, which can be adequately compensated by an award of costs. Finally, whilst appreciating that good faith is irrelevant in a claim under s 77 of the Patents Act (see, generally, *Terrell on the Law of Patents* at para 24-15), I should also state that this is not a case where the threats were completely baseless and unfounded. The nameplates of the IDEALmold machines which stipulate "ASM Pacific Technology" as the manufacturer arguably provided some basis for the plaintiff's threats, even though the plaintiff ultimately turned out to be wrong (see [111]-[120] above).

Conclusion

165 In conclusion, I find that the Patent has been infringed by the first defendant. As against the first defendant, the plaintiff is therefore entitled to: (a) a declaration that the Patent has been infringed by the first defendant; (b) an inquiry as to damages or, alternatively, at the plaintiff's option, an account of profits and an order for payment of all sums found due upon making such inquiry

or account; and (c) interest at 5.33% per annum.

166 There is no liability for infringement on the part of the second defendant and the Suit is dismissed in so far as it is concerned. There is also no liability for making groundless threats of infringement proceedings on the part of the plaintiff.

167 I will hear counsel on the issue of costs.

Copyright © Government of Singapore.